



Model TSA-RMG

# REVOLUTION™ MITER GAUGE OWNER'S MANUAL



*RMG™*

85-006132-00  
Rev C - Jan 2024

# TABLE OF CONTENTS

THANK YOU .....	4
WARRANTY .....	4
SAFETY .....	4
<b>ASSEMBLY &amp; INSTALLATION .....</b>	<b>5</b>
UNPACKING - WHAT'S IN THE BOX .....	5
REQUIRED TOOLS .....	6
INSTALL THE GRIP .....	6
INSTALL THE VERTICAL FACEPLATE .....	6
ADJUST THE MITER BAR FIT .....	7
Steps for Adjustment .....	8
ATTACH AND ADJUST THE FENCE .....	8
INSTALL THE FLIP STOP ASSEMBLY .....	10
<b>BASIC USE .....</b>	<b>10</b>
SET THE MITER ANGLE .....	11
Whole Degree Increments .....	11
Reading the Miter Angle .....	12
Fractional Degree Increments .....	13
USING THE FENCE SYSTEM .....	14
Setting Safe Fence Distance from Blade .....	14
Reversing the Fence Orientation .....	14
USING THE FENCE EXTENSION .....	15
POSITION THE FLIP STOP - GROSS ADJUSTMENTS .....	16
POSITION THE FLIP STOP - FINE ADJUSTMENTS .....	17
RETRACT THE FLIP STOP .....	18
<b>ADVANCED FEATURES .....</b>	<b>18</b>
MAKING FLIP STOP PRESETS .....	18
ADDING A SACRIFICIAL FENCE .....	19



Using the Adjustable Flip Stop With a Sacrificial Fence ..... 21

More About Shop-Built Jigs and Fixtures ..... 21

**CALIBRATION ..... 21**

SQUARE THE MITER ANGLE ..... 21

SQUARE THE MITER GAUGE WITH YOUR SAW ..... 22

ZERO THE FENCE RULER ..... 23

    Time Saving Tip (optional) ..... 25

ADJUSTING PLAY IN THE GEAR CLUSTER ..... 25

**TROUBLESHOOTING ..... 27**

Copyright SawStop, LLC  
All Rights Reserved

Published, January, 2024

Updates of this manual may be available at [SawStop.com](http://SawStop.com)

SawStop, the SawStop blade logo, REVOLUTION and RMG  
are trademarks of SawStop, LLC.

Patent pending.



## THANK YOU

Thank you for purchasing the SawStop Revolution Miter Gauge. This product has been carefully designed, rigorously tested, and contains innovations not seen before in the market place. We want you to get the most out of this product. To ensure the best possible experience, please read the instructions in their entirety prior to use. In this manual, you will find detailed instructions for the correct, accurate, and safe operation of your miter gauge.

## WARRANTY

SawStop warrants to the original retail purchaser of a new Revolution Miter Gauge from an authorized SawStop distributor that the Revolution Miter Gauge will be free from defects in material and workmanship for ONE YEAR from the date of purchase.

This warranty does not apply to defects arising from misuse, abuse, negligence, accidents, normal wear-and-tear, unauthorized repair or alteration, or lack of maintenance. This warranty is void if the Revolution Miter Gauge or any portion of the Revolution Miter Gauge is modified without the prior written permission of SawStop, LLC, or if the Revolution Miter Gauge is located or has been used outside of the country where the authorized SawStop distributor from whom the product was purchased resides.

Please contact SawStop to take advantage of this warranty. If SawStop determines the Revolution Miter Gauge is faulty in material or workmanship, and not due to misuse, abuse, negligence, accidents, normal wear-and-tear, unauthorized repair or alteration, or lack of maintenance, then SawStop will, at its expense and upon proof of purchase, send replacement parts to the original retail purchaser necessary to cure the defect.

SawStop disclaims any and all other express or implied warranties, including merchantability and fitness for a particular purpose. SawStop shall not be liable for death, injuries to persons or property, or incidental, consequential, contingent or special damages arising from the use of this Revolution Miter Gauge.

This warranty gives you specific legal rights. You may have other rights which, in the United States, vary from state to state.

## SAFETY

- Be sure to wear hearing protection, eye protection, and follow all normal shop safety practices at all times.
- Before starting any cutting/milling operations with your Revolution Miter Gauge, always securely tighten the large vertical grip/handle first.
- Never let the saw blade or cutter in your machine come in contact with any component of your Revolution Miter Gauge. Verify that nothing but the material you intend to cut or mill is in the path of the blade before turning on the tool.
- Always take care to keep your hands clear of blade or cutter of the tool that you've chosen to use your miter gauge with.
- When using the flip stop accessory to position a workpiece for cutting/milling operations, always hold or otherwise secure the board against the miter gauge fence as you guide the workpiece past the cutter or blade.
- After re-positioning the fence, be sure the two knurled, silver thumbscrews that secure the fence to the body of the miter gauge are sufficiently tightened.

### **IMPORTANT:**

The scope of this manual does not include instructions for the machine you are using the Revolution Miter Gauge with. These instructions assume you are competent and qualified in the safe and proper operation of the machinery you have chosen to accessorize with this miter gauge.

# ASSEMBLY & INSTALLATION

In this section, you will be instructed on how unpack and prepare your Revolution Miter Gauge (RMG) for use.

## UNPACKING - WHAT'S IN THE BOX

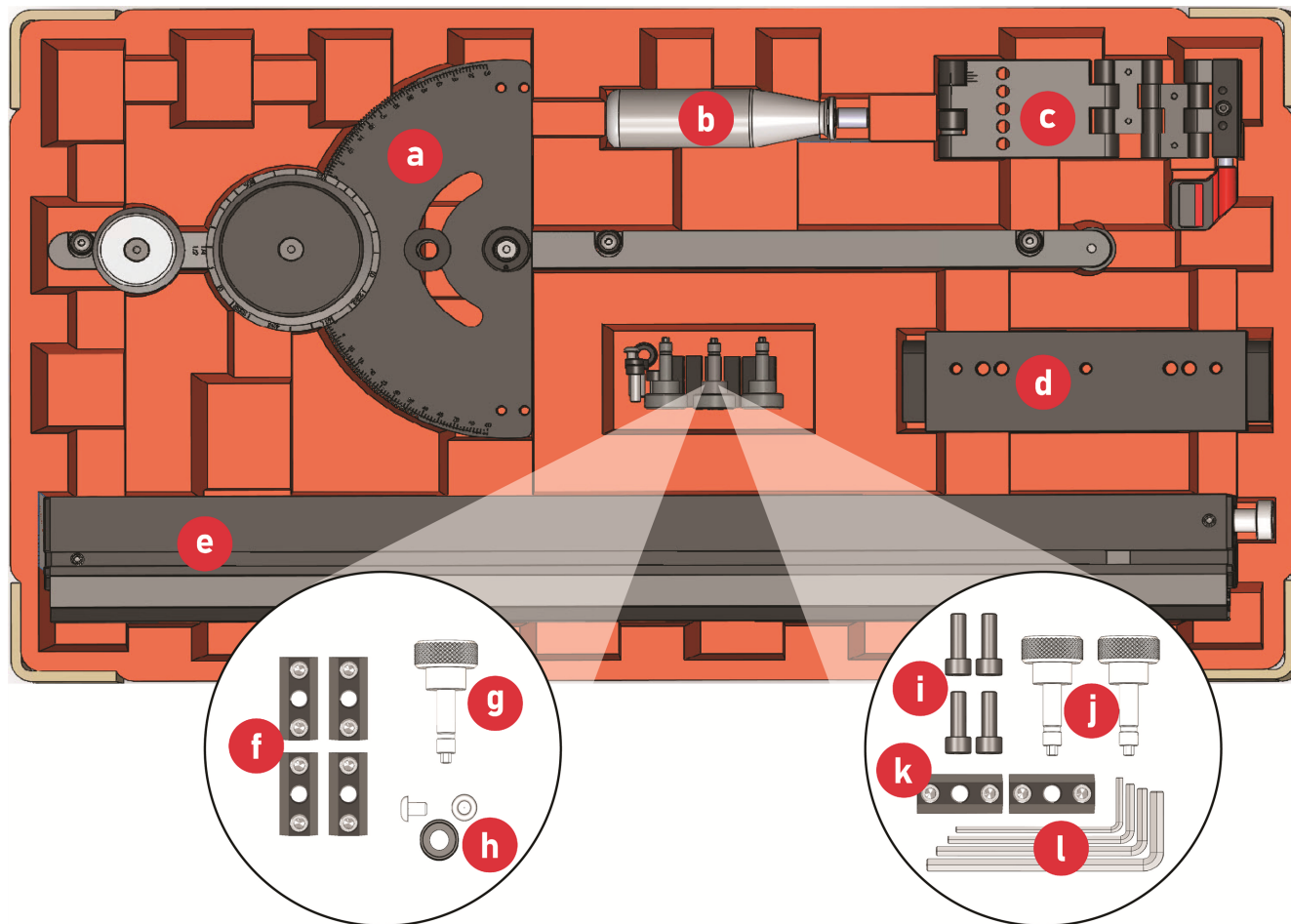

Included with your Revolution Miter Gauge are the following items. Unpack your miter gauge and confirm that everything is accounted for.

### Major Components:

- a. Miter Gauge Body (pre-assembled)
- b. Grip
- c. Flip Stop Assembly
- d. Vertical Faceplate
- e. Fence Assembly

### Spare Parts Bag Containing:

- f. Sliding Wedge (4)
- g. Thumbscrew (1)
- h. Replacement Miter Bar Adjustment Disc Kit

### Assembly Parts Bag Containing:

- i. Socket-Head Bolt, M5, 14mm (4)
- j. Thumbscrew (2)
- k. Sliding Wedge (2)
- l. Hex Wrenches: 2mm, 2.5mm, 3mm, and 4mm

### **! IMPORTANT:**

The main assembly of your miter gauge is secured from movement during shipping with a hex head bolt. This bolt can be removed and discarded. However, **DO NOT DISCARD THE WASHER!** Set it aside for assembly (described later in this manual).

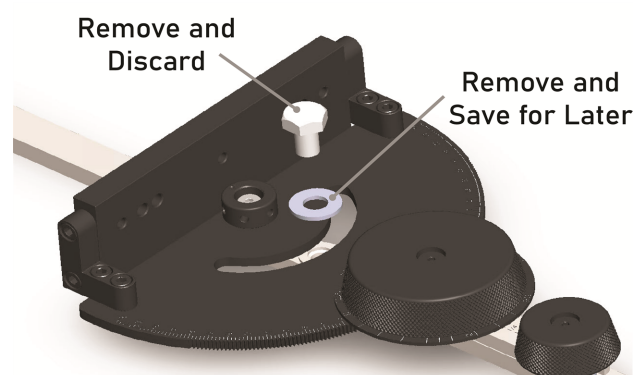

## REQUIRED TOOLS

- 2.5mm Hex Wrench (included)
- 3mm Hex Wrench (included)
- 4mm Hex Wrench (included)

## INSTALL THE GRIP

1. Place the flat washer you removed during unpacking as shown.

2. Thread the *Grip* into the hole on the miter bar by turning the *Grip* clockwise.

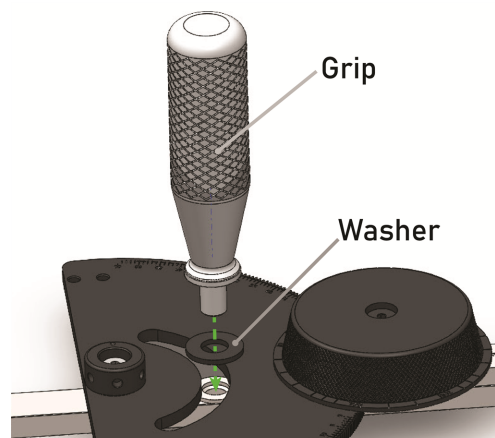

## INSTALL THE VERTICAL FACEPLATE

1. Attach the *Vertical Faceplate* to the *Miter Gauge Body* using the four *Socket-Head Bolts* from the hardware bag and the included 4mm hex wrench. Do not fully tighten.

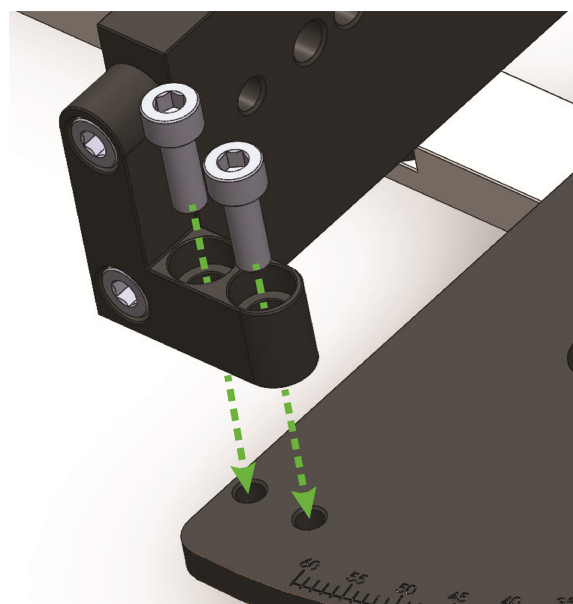

- Note that the diameter of the holes in the L brackets are slightly oversized to provide for precise positioning (squaring) of the *Vertical Faceplate* with the rest of the assembly. To prepare for squaring, loosen the *Grip* slightly by turning it counter-clockwise.

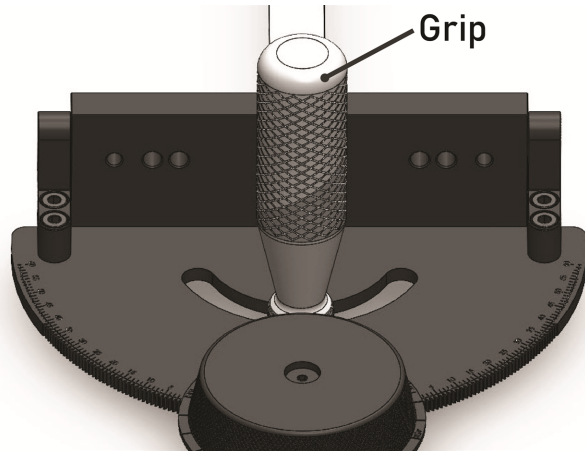

- Set the miter angle at 0° by rotating the *Miter Angle Dial*. To set the miter angle, read the protractor marking at the edge of the *Miter Angle Dial*.

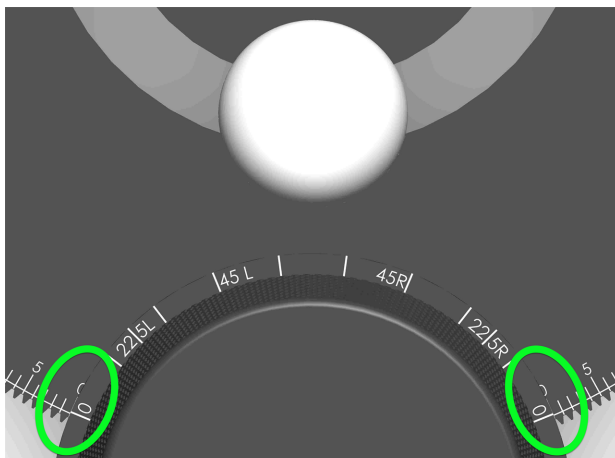

- After selecting 0°, tighten the *Grip* by rotating it clockwise.

- Use a precision square against the side of the miter bar without expansion discs to square the *Vertical Faceplate* as you finish tightening the four *Socket-Head Bolts* you inserted in step 2. Use the included 4mm hex wrench.

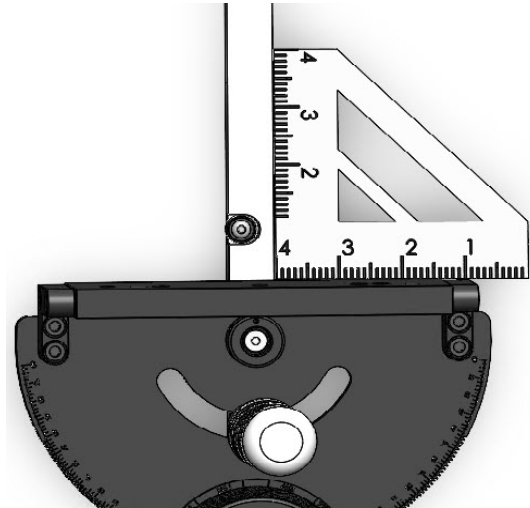

## ADJUST THE MITER BAR FIT

Follow the instructions below to ensure the miter bar of your Revolution Miter Gauge is optimally fitted to the miter slot in your machine. Perform this procedure prior to altering any other points of fine calibration discussed later in this manual.

### ! IMPORTANT:

If the Revolution Miter Gauge is moved between multiple tools in your shop (e.g. a table saw and bandsaw), be mindful that miter gauge slot dimensions may vary slightly between tools. When the miter bar fit is optimized for one machine, the fit may be less than optimal when used with a different tool. For best results, the steps described below should be repeated before using this miter gauge in a different machine than the tool for which the miter bar was previously fitted.

## Steps for Adjustment

1. Place the miter bar into the slot of the machine you intend to use the Revolution Miter Gauge with.
2. Using the provided 2.5mm hex wrench, loosen and then fully tighten each of the three discs along the length of the miter bar.

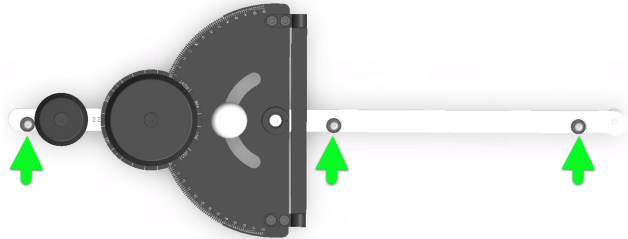

Begin with the middle adjustment disc, then adjust the front disc. Adjust the disc at the rear of the miter bar last.

### ! IMPORTANT:

The optimal fit strikes a balance between minimizing side-to-side play of the miter bar while preserving easy travel of the miter gauge along the length of the miter slot. If the miter gauge offers too much friction when passing material across the table of your machine, loosen the adjustment described above to relieve the excessive friction.

If you're having trouble optimizing the fit, try using a piece of paper as a spacer between each adjustment disc and the side of the miter slot when performing this procedure.

## ATTACH AND ADJUST THE FENCE

The setup described here assumes the miter gauge will be used in the miter slot to the left of the blade. If your use case requires setting up your miter gauge for use in the right side miter slot, see the instructions for **Reversing the Fence Orientation** on page 14.

Follow the steps below to attach the black, aluminum-extruded *Fence Assembly* to the body of the miter gauge.

1. From the back of the *Vertical Faceplate*, insert a silver, knurled *Thumbscrew* through the "Center" hole indicated in the illustration below.

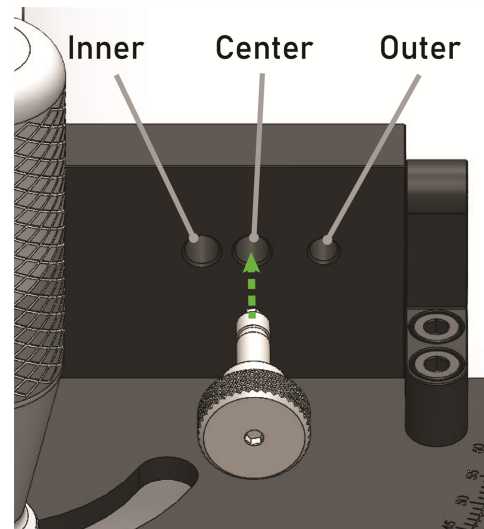

2. At the front of the *Vertical Faceplate*, loosely thread one of the *Sliding Wedges* onto the tip of the knurled *Thumbscrew*.

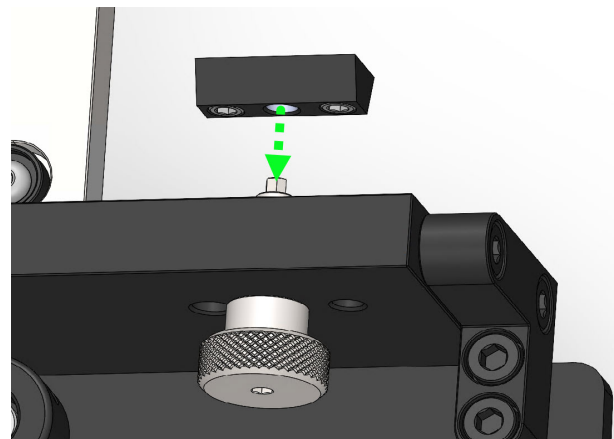



- Repeat steps 1 and 2 using a second *Thumbscrew* and *Sliding Wedge* as shown.

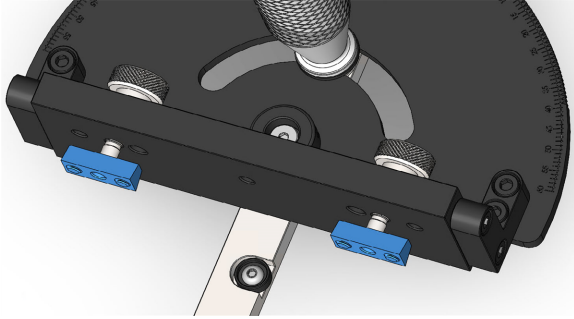

- Orient the *Fence Assembly* such that the ruler is facing up and the end with the silver, knurled *Fence Extension Release* is positioned at left (furthest from the blade).

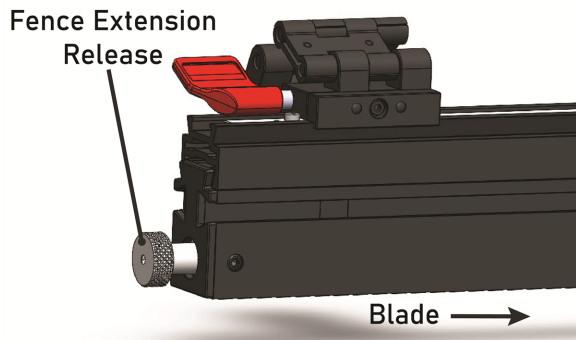

- Align the dovetail shaped slot in the back of the *Fence Assembly* with the pair of *Sliding Wedges* you installed in step 2. Slide the *Sliding Wedges* through the slot.

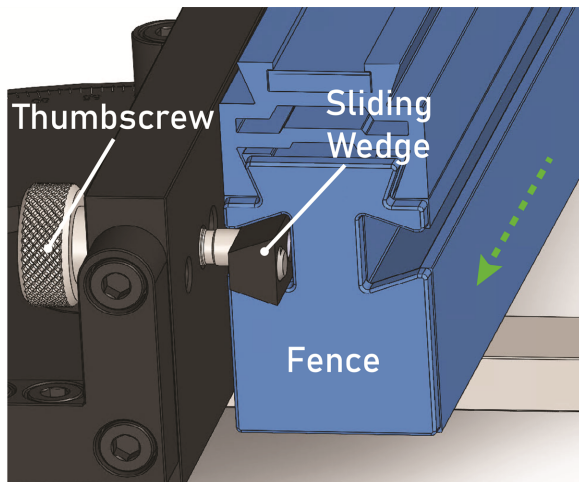

- With the machine powered off, place the miter gauge into the miter slot of your machine. Move the miter gauge down the length of the miter slot and confirm that no part of the *Fence Assembly* is in the path of the blade. See additional details about **USING THE FENCE SYSTEM** on page 14.

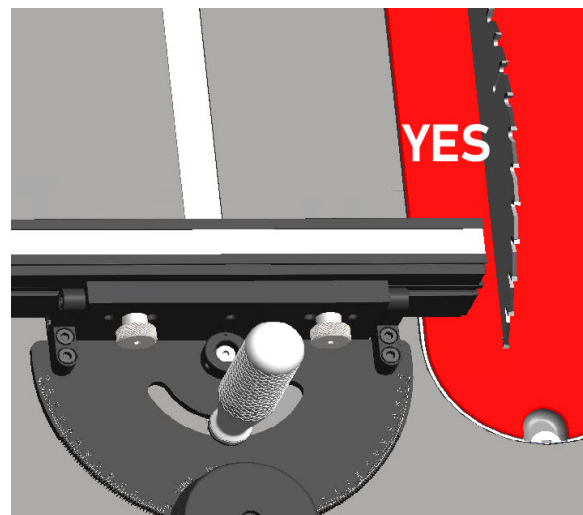
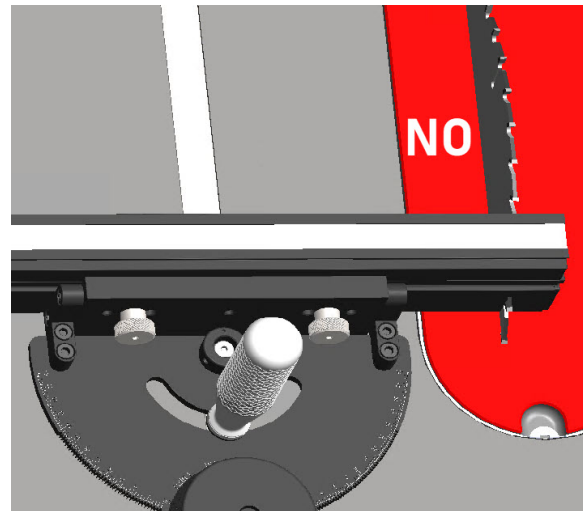

- Adjust the *Fence Assembly* to the left or right as needed, then tighten the *Thumbscrews* on the back side of the *Miter Gauge Body* to secure the fence from moving during cutting operations.



### WARNING:

If you change the miter angle, the clearance between the fence and blade may also change. To minimize risk of injury and damage to your miter gauge, re-confirm that a safe margin of clearance is present (described above) after any miter angle adjustment is made.

## INSTALL THE FLIP STOP ASSEMBLY

Use the following steps for initial installation of the *Flip Stop Assembly*.

1. Move the red flip stop release lever to the 10 o'clock position as shown to open the clamp on the underside of the *Flip Stop Assembly*. Slide the bottom of the *Flip Stop Assembly* over the end of the top rail of the *Fence Assembly* extrusion.

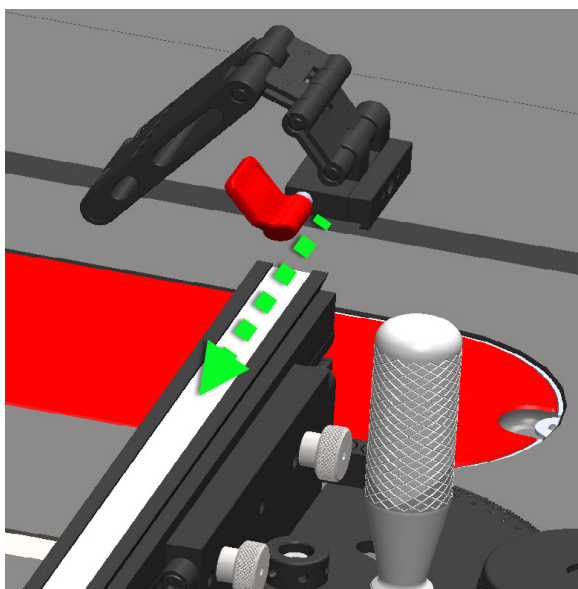

2. Continue to slide the *Flip Stop Assembly* along the top of the *Fence Assembly* extrusion to the desired distance from the blade.

3. Move the red flip stop release to the 2 o'clock position (as shown) to secure the *Flip Stop Assembly* in place.

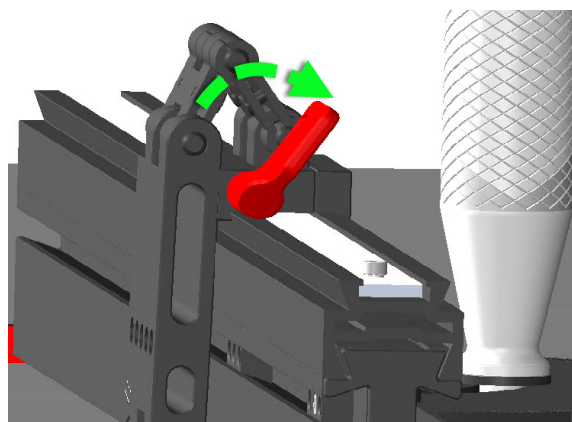

4. The *Flip Stop Assembly* is now installed and positioned for your first cut. Reposition the *Flip Stop Assembly* as needed for future cuts by releasing the red, flip stop clamp as described above, then securing it again at the new location.

If the flip stop hinges are sticky or difficult to move, adjust the small hex bolt in the hinge body using the provided 2mm hex wrench.

Be sure to visit the section on **CALIBRATION** on page 21 of this manual for instructions on setting up the built-in ruler to read accurately.

Congratulations! The assembly of your Revolution Miter Gauge is now complete.

## BASIC USE

This portion of the manual discusses basic use of your Revolution Miter Gauge such as setting the miter angle, using the fence system, and how to use the adjustable flip-stop system. The main controls on your Revolution Miter Gauge are labeled in the next illustration. These controls are referenced by name in the instructions that follow.

## SET THE MITER ANGLE

Learning to use your Revolution Miter Gauge first requires an understanding of the main controls.

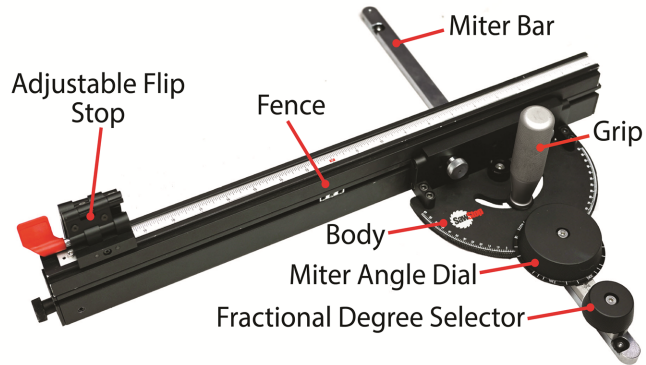

### ! IMPORTANT:

To set the miter angle, DO NOT grab the fence and rotate it in relation to the miter bar. Your SawStop Revolution Miter Gauge is unlike any other in the marketplace. Follow the instructions in this chapter to learn its unique controls and proper method for setting the miter angle.

## Whole Degree Increments

Follow the steps below to set the miter angle on your Revolution Miter Gauge for whole degree increments.

1. Loosen the *Grip* slightly by rotating it counter-clockwise.

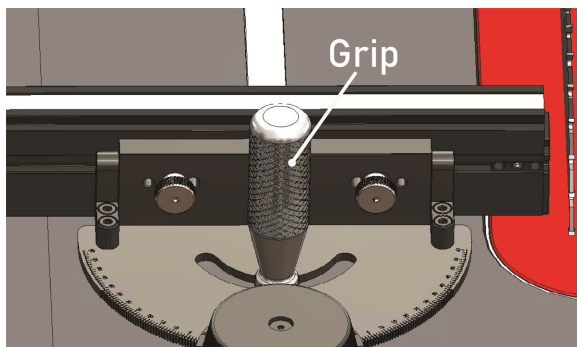

2. Set the *Fractional Degree Selector* to "1".

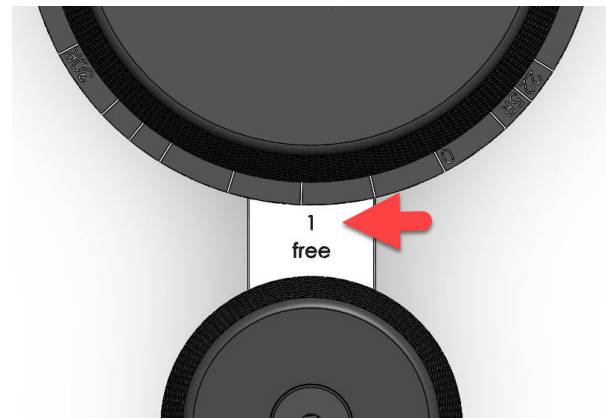

3. Rotate the *Miter Angle Dial* until the desired miter angle is indicated, then re-tighten the *Grip*. The example image below shows a 15° left miter angle.

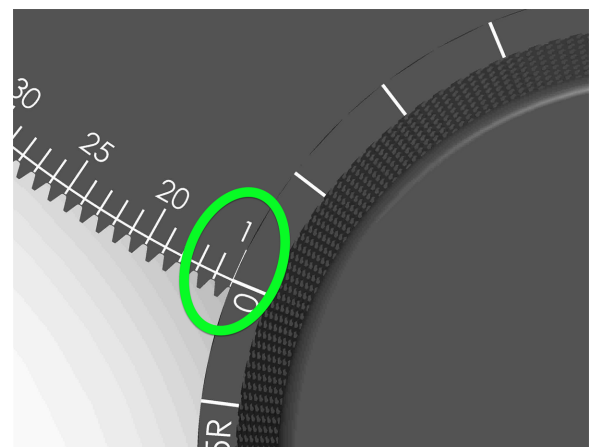

## Reading the Miter Angle

Read the miter gauge where the numbers on the body/protractor align with the edge of the *Miter Angle Dial*.

**EXAMPLE 1:** 45° on the protractor is aligned with the edge of the *Miter Angle Dial* indicating that the miter is set for 45° left angle.

For this, and other common miter angles (e.g. 22.5° and 30°), note that there are also markings around perimeter of the *Miter Angle Dial*. (These dial markings should be ignored when setting other angles.) In this example, the 45L marking on the dial is aligned with the arc-shaped line on the protractor.

The dual indication described in this example only applies to miter angles at full degree increments.

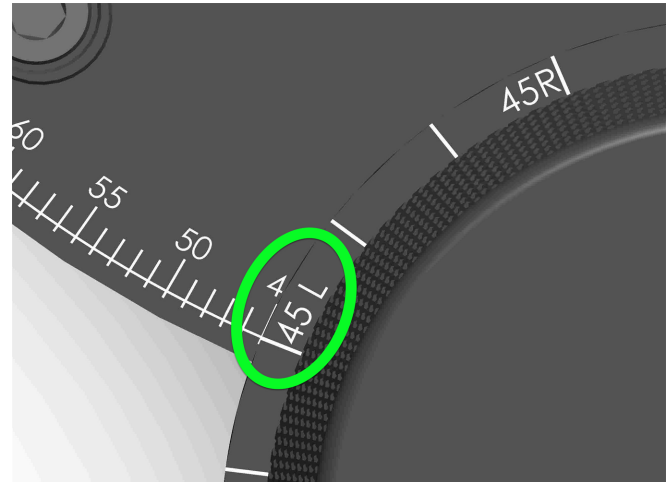

**EXAMPLE 2:** 0° on the protractor is aligned with the edge of the *Miter Angle Dial* indicating that the miter is set for 0 degrees.

As in first example, the 0 marking on the edge of the *Miter Angle Dial* is also aligned with the arc-shaped line on the protractor.

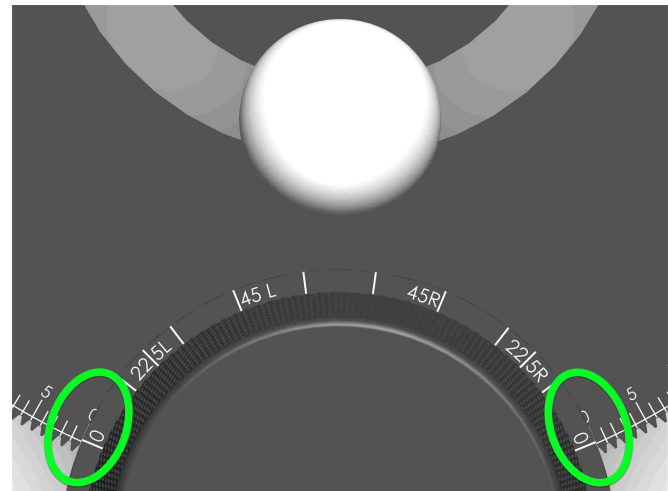

**EXAMPLE 3:** 52° on the protractor is aligned with the edge of the *Miter Angle Dial* indicating that the miter is set for 52° right angle.

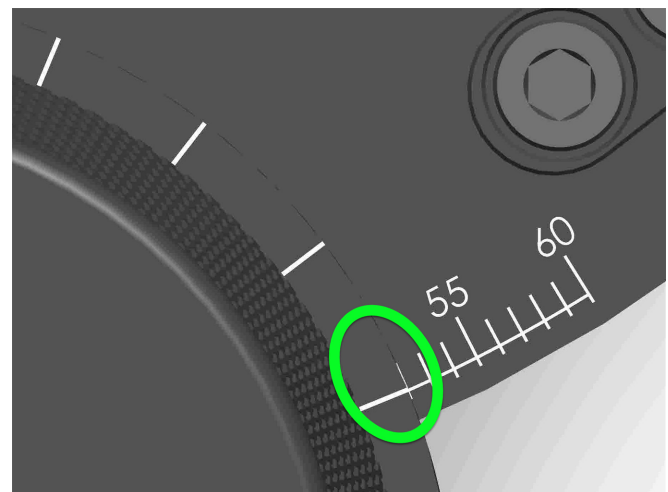

## Fractional Degree Increments

Should you require miter angle precision greater than whole degree increments (as described above), use the *Fractional Degree Selector* to choose the desired degree of precision. Changing this selector affects the sensitivity of the *Miter Angle Dial* giving a more coarse or fine response to inputs to the dial.

To read the setting for the *Fractional Degree Selector*, look just beneath the *Miter Angle Dial*. In the example shown, the selector is set at  $1/4^\circ$ .

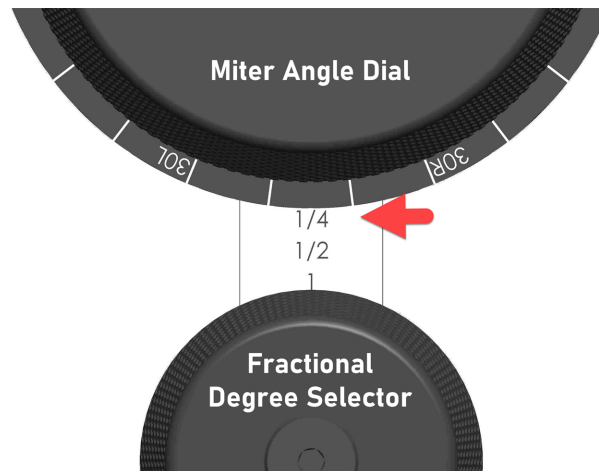

The available settings for the *Fractional Degree Selector* and their significance are described in the table below.

Fractional Degree Selector Setting	Effect
1/10	Ten detents are felt between each whole degree as you rotate the <i>Miter Angle Dial</i> . Count the "clicks" as you turn the dial between whole degree markings on the protractor to achieve $1/10^\circ$ accuracy of the miter angle setting.
1/4	Four detents are felt between each whole degree as you rotate the <i>Miter Angle Dial</i> . Count the "clicks" as you turn the dial between whole degree markings on the protractor achieve $1/4^\circ$ accuracy of the miter angle setting.
1/2	One additional detent is felt between each whole degree as you rotate the <i>Miter Angle Dial</i> . Count the extra "click" between whole degree markings on the protractor to select $1/2^\circ$ miter angle settings.
1	Each "click" of the <i>Miter Angle Dial</i> adjusts the miter angle setting by increments of one full degree.
Free	This setting completely disengages the internal gear cluster such that only one detent is felt per rotation (once every $24^\circ$ ) of the <i>Miter Angle Dial</i> .

## USING THE FENCE SYSTEM

The 22 inch *Fence Assembly* on your Revolution Miter Gauge offers extended support for bigger material but also has some added benefits. Those additional features and how to use them are discussed below.

### Setting Safe Fence Distance from Blade

To ensure maximum support of the workpiece, position the *Fence Assembly* to run close to the blade where friction on the workpiece is greatest during cutting operations. Be sure there is an adequate margin for safety.

1. With the machine powered off, place the miter gauge into the miter slot. Move the miter gauge down the length of the miter slot and confirm that no part of the *Fence Assembly* is in the path of the blade.

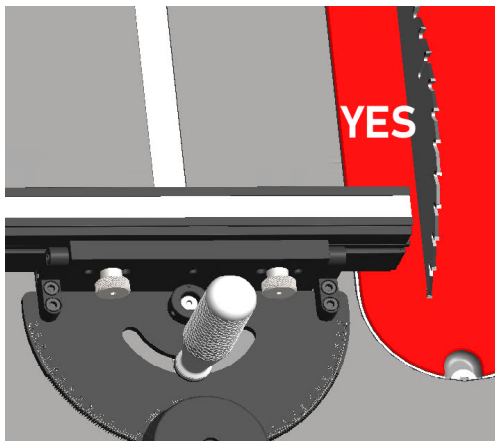
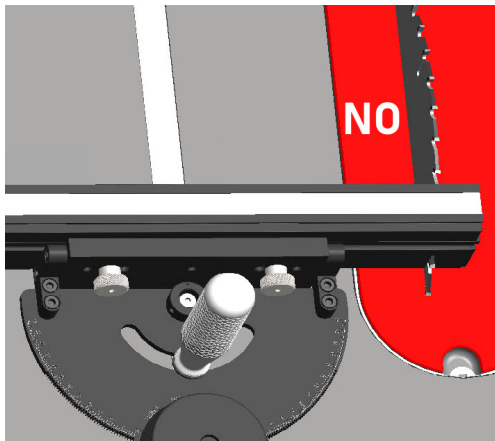

2. Adjust the *Fence Assembly* to the left or right as needed, then tighten the *Thumbscrews* on the back

side of the miter gauge body to secure the fence from moving during cutting operations.

### **WARNING:**

If you change the miter angle, the clearance between the fence and blade may also change. To minimize risk of injury and damage to your miter gauge, re-confirm that a safe margin of clearance is present (described above) after any miter angle adjustment is made.

### **IMPORTANT:**

The built-in ruler on the miter gauge *Fence Assembly* is used in tandem with the adjustable flip stop. For measurement readings on the ruler to be meaningful, specific setup steps related to positioning of the *Fence Assembly* in relation to the blade are required. See **ZERO THE FENCE RULER** on page 23 for detailed instructions.

### Reversing the Fence Orientation

The Revolution Miter Gauge fence is fully configurable to facilitate use of the miter gauge in the miter slot to the left or the right of a table saw blade. The dovetail-shaped slot is identical on the front and back side of the *Fence Assembly* extrusion to enable this versatility.

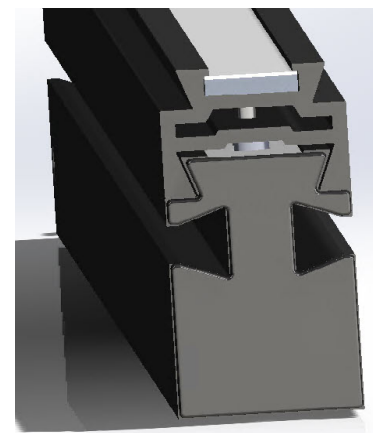

Should you need to use the miter gauge in the right-side miter slot, use the same installation method described

earlier in this manual, with the exception of the *Fence Assembly* orientation. Instead, the silver, knurled knob at the end of the fence should be positioned at the right (furthest from the blade) before guiding the slot in the fence onto the *Sliding Wedges*.

Once the *Fence Assembly* has been reversed as described above, fold the flip stop over so that it is once again forward facing.

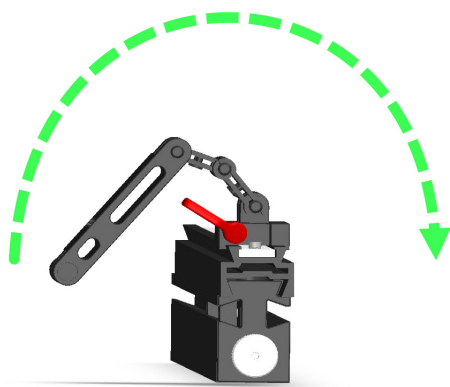

## USING THE FENCE EXTENSION

The fence extension works in tandem with the adjustable flip stop. To ensure you get full advantage of these features, be sure to read and understand both this chapter and the chapter for **POSITION THE FLIP STOP - GROSS ADJUSTMENTS** on the next page.

The fence extension is used in conjunction with the flip stop to give you repeatable, fixed-length cuts that are longer than would be possible without the extension.

When using the flip stop without extending the fence, you can make fixed-length cuts from 0-19.5". In this range, the measurement for the flip stop setting is read at the edge of the adjustable flip stop carrier that is closest to the blade.

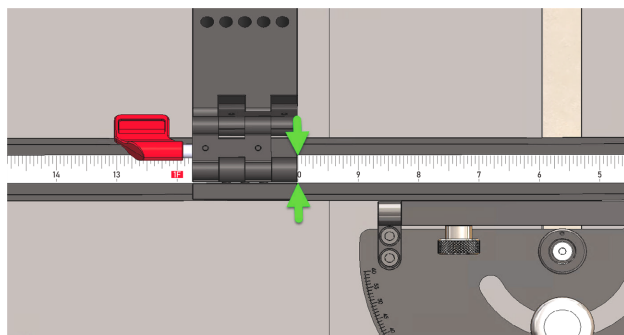

The fence extension comes into play when fixed-length cuts longer than 19.5" are required. Follow the steps below to set your flip stop and fence for this extended cut capacity.

1. Move the *Flip Stop Assembly* across the top rail of the *Fence Assembly* until it is against the small cap screw near the end of the fence rail.

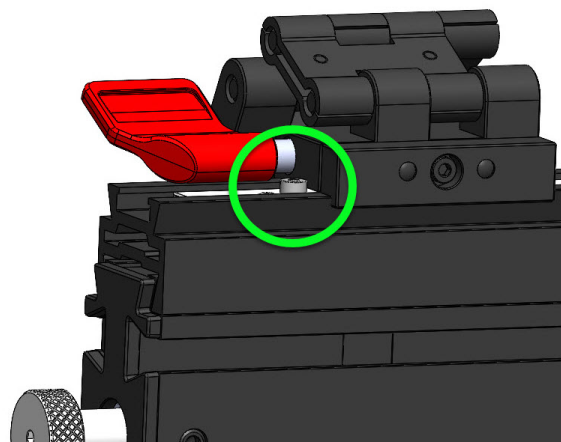

2. Move the red flip stop release lever to the 2 o'clock position to secure the *Flip Stop Assembly* in place.
3. Loosen the silver *Fence Extension Release* by rotating it counter-clockwise.

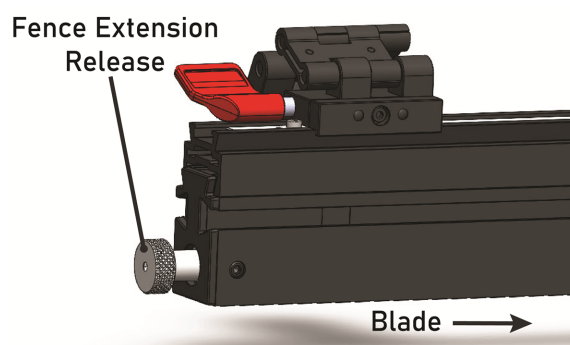

4. Draw the upper portion of the *Fence Assembly* extrusion to the side to extend the fence.

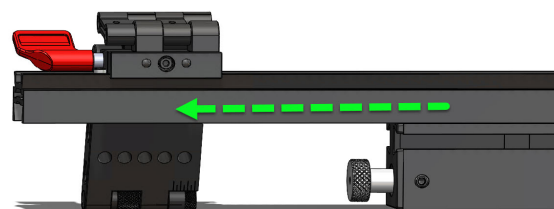

5. Read the lower ruler here to determine the length of cut.

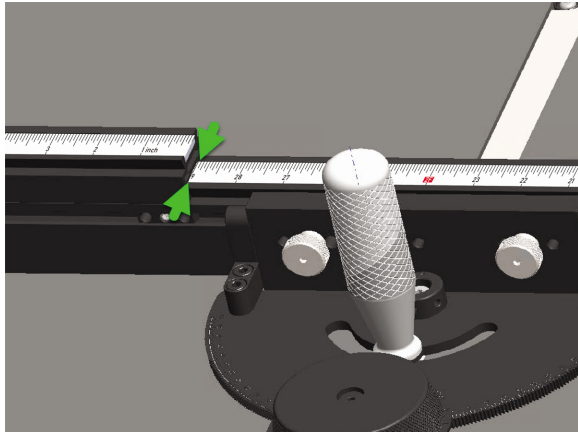

6. When you reach the desired extension length, re-tighten the silver, knurled *Fence Extension Release* by rotating it clockwise until it feels locked.

**! IMPORTANT:**

To ensure measurement accuracy when utilizing the flip stop in conjunction with the telescoping fence extension, always begin by positioning the *Flip Stop Assembly* as described above in step 1. Also, confirm that you have followed the instructions for **ZERO THE FENCE RULER** on page 1.

## POSITION THE FLIP STOP - GROSS ADJUSTMENTS

Your Revolution Miter Gauge is equipped with a moveable stop that works in conjunction with the *Fence Assembly*. It can be re-positioned along the length of the fence to provide for repeatable, fixed-length cuts. Just position the stop where you want it, butt your workpiece against the stop, then make the cut.

1. Move the red, flip stop release lever to the 10 o'clock position as shown to open the clamp on the underside of the *Flip Stop Assembly*.

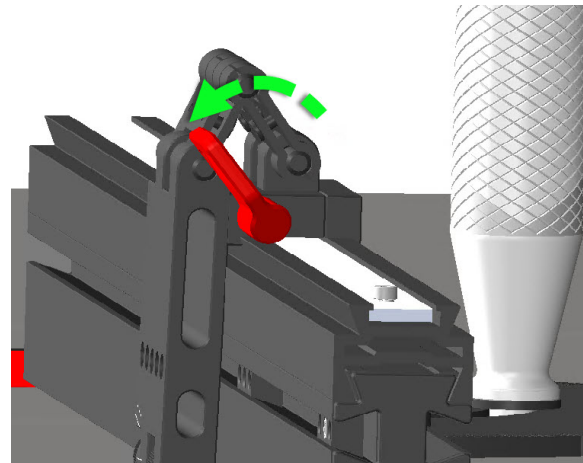

2. Slide the *Flip Stop Assembly* along the top of the *Fence Assembly* extrusion to the desired distance from the blade. Read the built-in ruler on the fence at the edge of the flip stop carrier here.

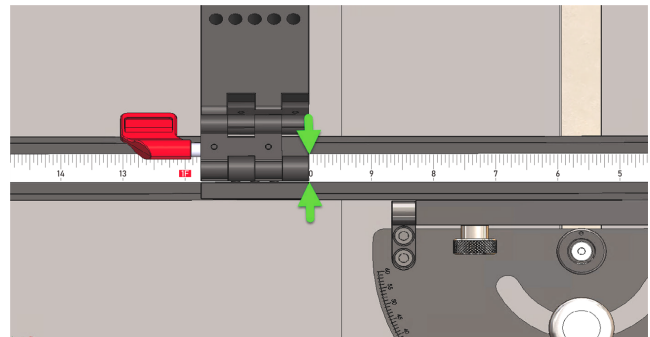

**! IMPORTANT:**

To ensure accurate readings from the ruler attached to the *Fence Assembly* of your Revolution Miter Gauge, be sure read the instructions for **CALIBRATION** on page 21 and **ZERO THE FENCE RULER** on page 23.



3. Move the red flip stop release lever to the 2 o'clock position as shown to secure the *Flip Stop Assembly* in place.

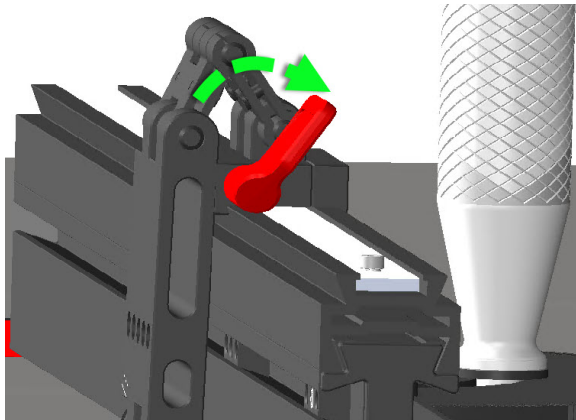

4. The *Flip Stop Assembly* employs a unique double-jointed hinge\*. Ensure that the flip stop is folded down as shown above so that it is flush to the face of the main fence extrusion.

\* The double-jointed hinge design can accommodate an optional, user-provided, sacrificial fence attached to the main *Fence Assembly* extrusion. See **USING THE FENCE SYSTEM** on page 14 for instructions.

## POSITION THE FLIP STOP - FINE ADJUSTMENTS

The fine adjustment feature for the flip stop of your Revolution Miter Gauge offers a greater precision not achievable with the method for positioning the *Flip Stop Assembly* described above. Use the following steps to take advantage of this precision feature.

1. Set a rough position for the *Flip Stop Assembly* following the instructions in the **Position the Flip Stop - Gross Adjustments** section above.

2. Back off the knurled *Jam Nut* on the precision adjustment by turning it counter-clockwise.

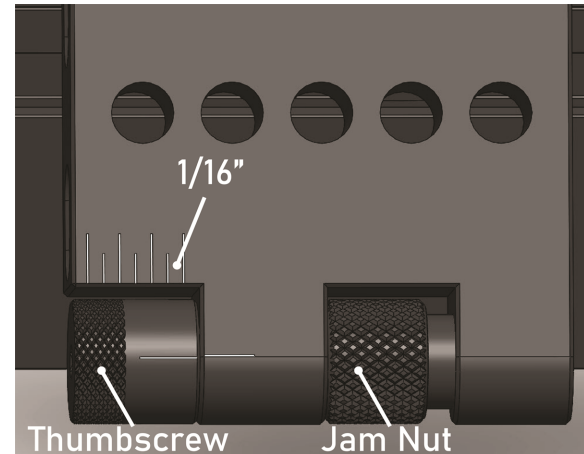

3. By rotating the black, knurled *Thumbscrew* at the tip of the fine adjustment shaft, you can shift the cut length to be shorter.
  - There are four horizontal markings around the circumference of the adjustment barrel at 1/64" intervals.
  - One full revolution of the fine adjustment barrel = 1/16".
  - Reference the vertical 1/16" markings on the flip stop just above the *Thumbscrew* to help count how many full revolutions from the flush position you have turned the adjustment barrel.
4. When the desired adjustment is set, re-tighten the jam nut that you loosened in step 2.

## RETRACT THE FLIP STOP

The flip stop is hinged for your convenience so that it can be easily moved out of the way. In between cuts of a specific length as set by the flip stop position, you may have an ad-hoc need for cutting a larger workpiece that requires the unobstructed, full-length support of the *Fence Assembly*. In that event, you can retract the flip stop as shown then move it back into position when resuming fixed-length cuts.

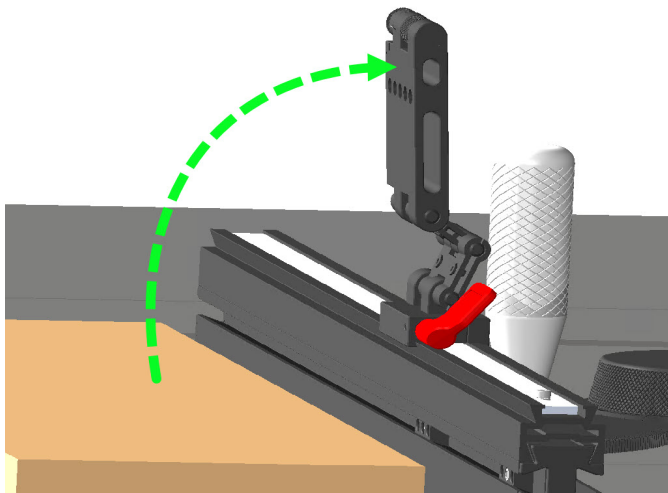

1. Referencing the built-in ruler, set the flip stop at 8". Move the red flip stop release lever to the 2 o'clock position as shown to secure the flip stop in place.

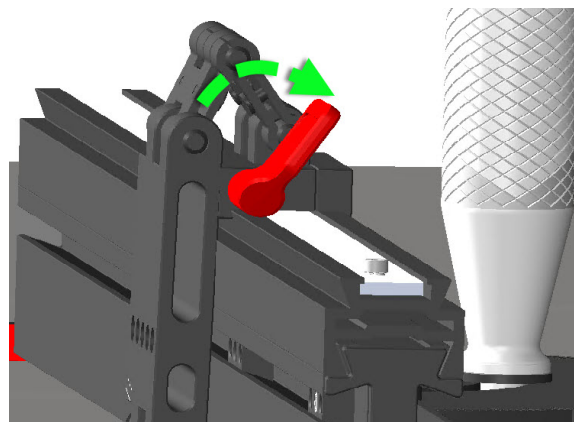

2. Insert a spare *Sliding Wedge* into the slot on the front of the *Fence Assembly* and position it behind the flip stop. Align the center hole of the *Sliding Wedge* (highlighted in blue) with the center hole on the front of the flip stop.

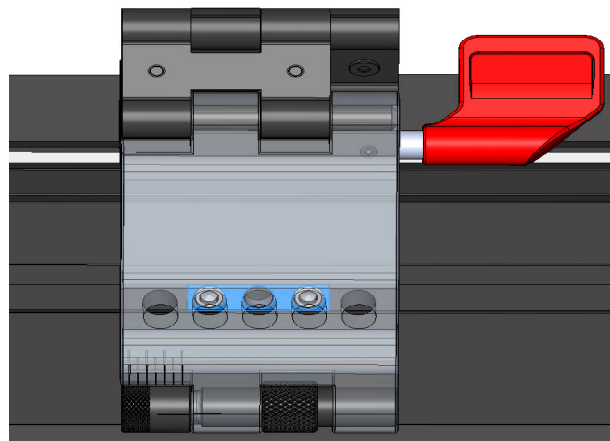

## ADVANCED FEATURES

Building on the basic functions you learned in the previous chapter, this chapter discusses additional, optional features of the Revolution Miter Gauge.

### MAKING FLIP STOP PRESETS

**SCENARIO:** Your project calls for alternating between multiple, fixed-length cuts using the flip stop. Your common required cut lengths are 8", 12", and 18".

**PROCEDURE:** Use the instructions below to make flip stop presets at 8", 12", and 18". For this procedure, you'll need 3 of the spare *Sliding Wedges* and the spare *Thumbscrew* (included).

3. Insert the spare *Thumbscrew* into the hole just left of the center hole of the flip stop. Use the hex tip of the *Thumbscrew* to tighten the set screw of the *Sliding Wedge* (highlighted in blue) you placed in Step 2. Turn the *Thumbscrew* clockwise until the set screw is snug.

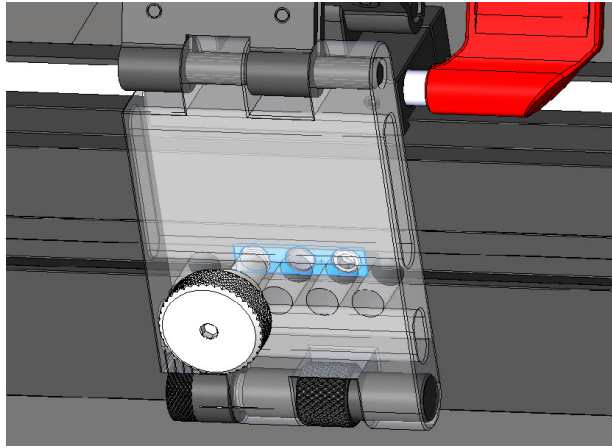

4. Move the *Thumbscrew* to the center hole on the flip stop and test that it can freely thread into the *Sliding Wedge* you installed in step 2. If the *Thumbscrew* does not thread freely, the *Sliding Wedge* may have been disturbed during the previous step. To fix this, loosen the set screw slightly, correct the position of the wedge, and repeat step 3.
5. Tighten the second set screw in the *Sliding Wedge* by inserting the spare *Thumbscrew* in the hole to the right of the center hole of the flip stop. Use the hex tip of the *Thumbscrew* to tighten the set screw. Turn the *Thumbscrew* clockwise until the set screw is snug.

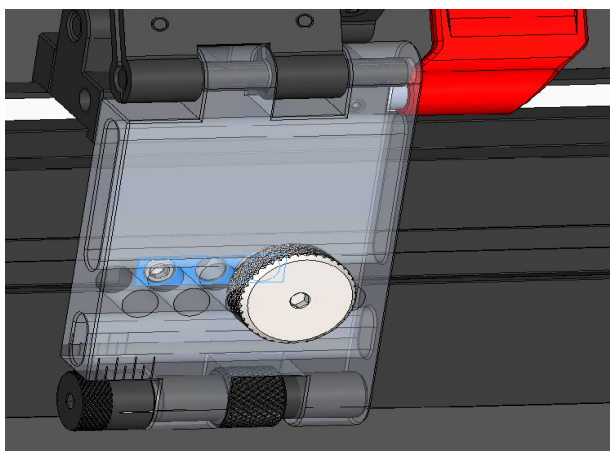

The *Sliding Wedge* is now fixed in place and your first preset is done.

6. Repeat steps 1-5 at the 12", and 18" positions. When all three flip stop presets (spare *Sliding Wedges*) are in place, it should resemble the image below. (Spare *Sliding Wedges* are highlighted in blue.)

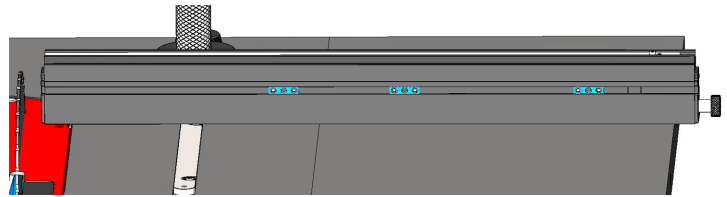

With these presets now in place, you can easily, and with precision, alternate between these cut lengths by indexing the center hole on the front of the flip stop with the presets (*Sliding Wedges*) you installed.

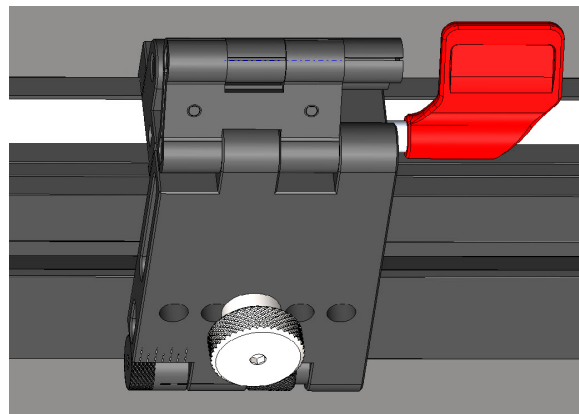

## ADDING A SACRIFICIAL FENCE

Adding a suitable material (not included) secured to the front of the aluminum *Fence Assembly* of your miter gauge can be achieved by taking advantage of the dovetail-shaped slot that runs the length of the face of the *Fence Assembly*. To secure the axillary fence material, add a pair of the spare *Sliding Wedges* that shipped with your miter gauge into the slot plus a pair of M6 bolts (not included). The length of the bolts will vary depending on the thickness of the material you choose for your sacrificial fence. (Detailed instructions to follow.)

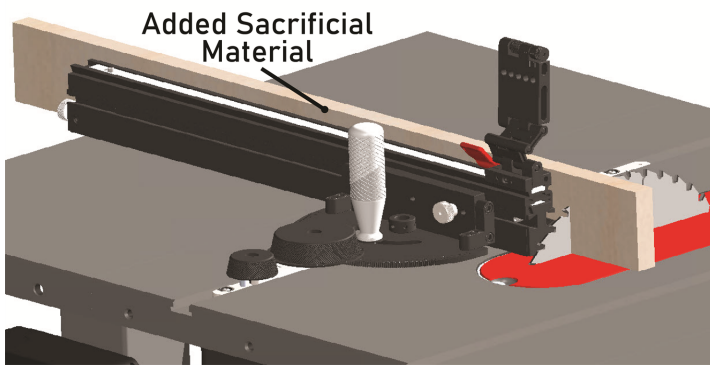

The advantages of this optional modification adds versatility to your fence system including...

- Extends the length of your fence to provide additional support for bigger workpieces.
- After securing the sacrificial piece and making an initial cut, there is now a visual reference for where the blade passes through. This is helpful for aligning a workpiece for the next cut.
- When making cuts, the waste to the right of the blade is supported and safely moved past the blade. This is applicable when the depth of cut is less than the height of the sacrificial fence. (Were the blade set too high, the sacrificial fence material past the blade would be cut completely off.)

**! IMPORTANT:**

Employing a sacrificial fence as described here typically requires the removal of the blade guard from your table saw and using the riving knife only. Proceed with this optional modification at your discretion.

Follow the instructions below to attach a sacrificial fence.

1. Distribute 2 of the spare *Sliding Wedges* across the length of the front of the miter gauge *Fence Assembly* as shown.

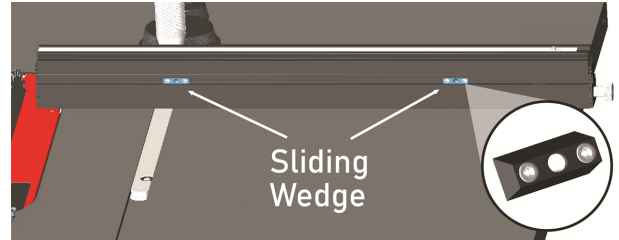

2. Using the spare, knurled *Thumbscrew* provided with your miter gauge, fix the wedges in place by tightening the set screws located on either side of the center hole in the *Sliding Wedges*.

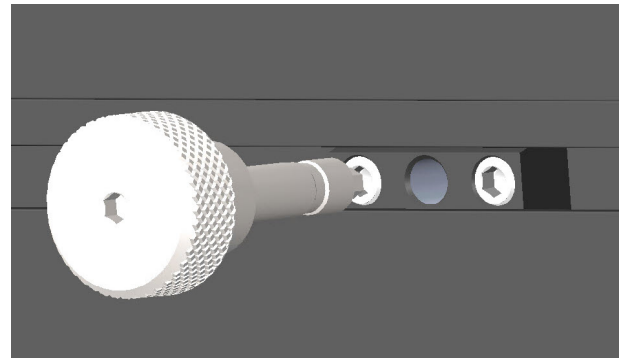

3. Prepare your sacrificial fence material: the dimensions should not exceed 3" tall and 3/4" thick. Drill two counter-sunk holes in the *Sliding Wedges* you installed in step 1.

- Attach the sacrificial piece you've prepared using two M6 bolts (not included). Insert the bolts through the counter-sunk holes in your sacrificial fence, then thread the bolts into the center hole of the *Sliding Wedges* you placed in Step 1.

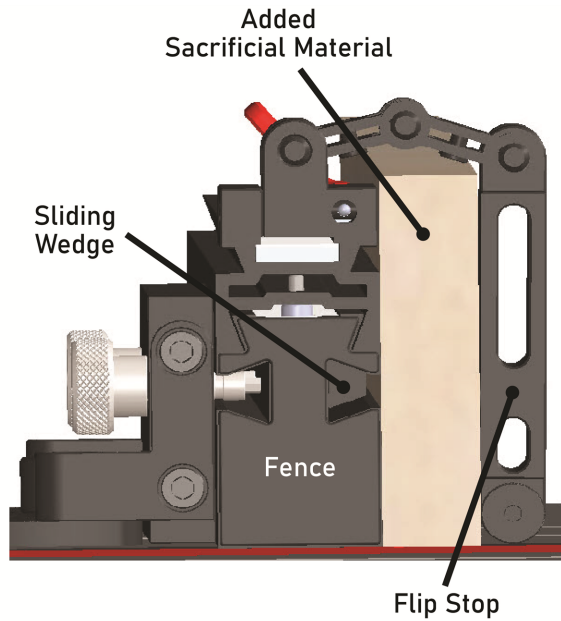

### Using the Adjustable Flip Stop With a Sacrificial Fence

Once you've added sacrificial fence material as described above, the adjustable flip stop can still be used thanks to its unique double-hinge joint design. Adjust the joints of the hinge as shown to conform to the additional thickness affixed to the factory fence.

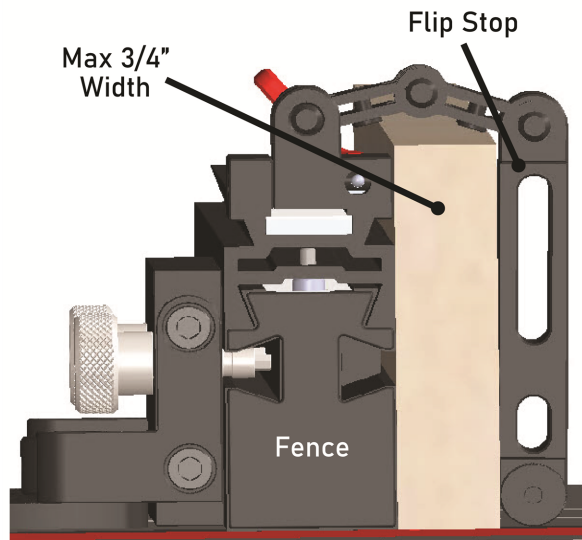

### More About Shop-Built Jigs and Fixtures

Beyond the auxiliary fence example discussed here, consider attaching your other shop-built fixtures using spare *Sliding Wedges* (included) by the same methods described above.

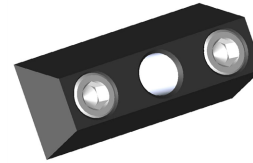

Alternatively, you can remove the *Fence Assembly* and attach your DIY fixtures and jigs directly to the *Miter Gauge Body* using M6x1.0 bolts threaded into outermost holes in the *Vertical Faceplate*.

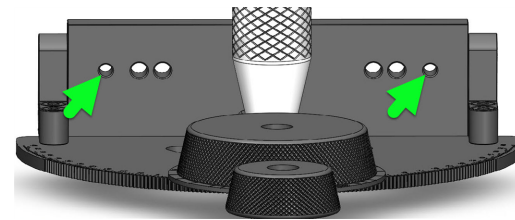

(M6 bolts not included.)

## CALIBRATION

Your Revolution Miter Gauge comes precision made by SawStop and is fully functional straight from the box. With the need for various fine adjustments to be made by the end user in mind, your miter gauge has been engineered to be calibrated in various ways. Instructions for these adjustments are discussed below.

### SQUARE THE MITER ANGLE

The diameter of the holes in the L brackets are slightly oversized to provide for precise positioning (squaring) of the *Vertical Faceplate* with the rest of the assembly. If you find that the miter angle precision is incorrect, the play available here gives the means to true the miter angle using the instructions below.

- Remove the *Fence Assembly* from the *Miter Gauge Body*.

- Loosen the *Grip* slightly and set the miter angle to 0° by rotating the *Miter Angle Dial*. To set the miter angle, read the protractor marking at the edge of the *Miter Angle Dial*.)

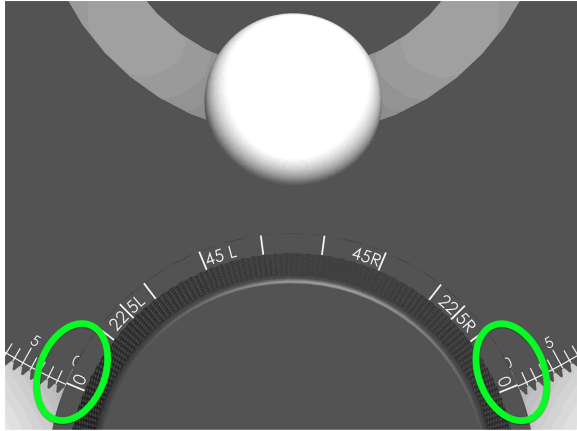

- After selecting 0°, tighten the *Grip* by rotating it clockwise.

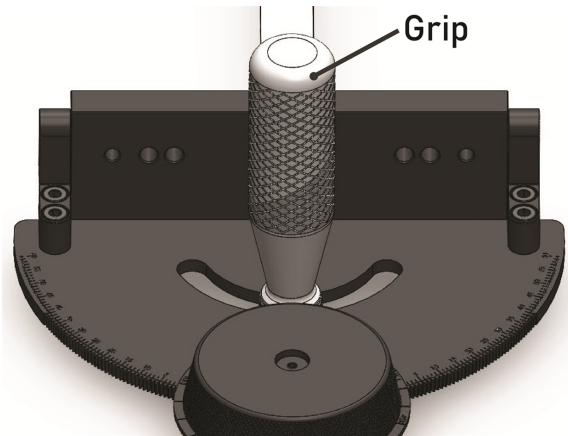

- Loosen the four *Socket-Head Bolts* slightly that secure the *Vertical Faceplate* to the *Miter Gauge Body*.

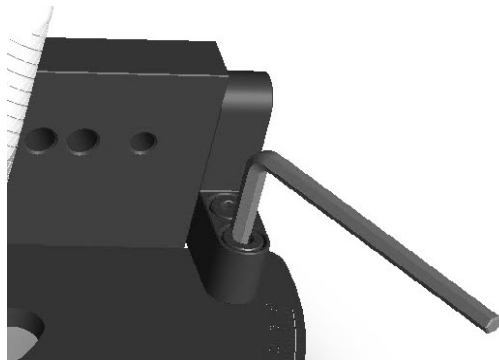

- Use a precision square against the side of the miter bar without expansion discs to square the

*Vertical Faceplate* as you re-tighten the four *Socket-Head Bolts* you loosened in step 4. Use the included 4mm hex wrench to tighten the bolts.

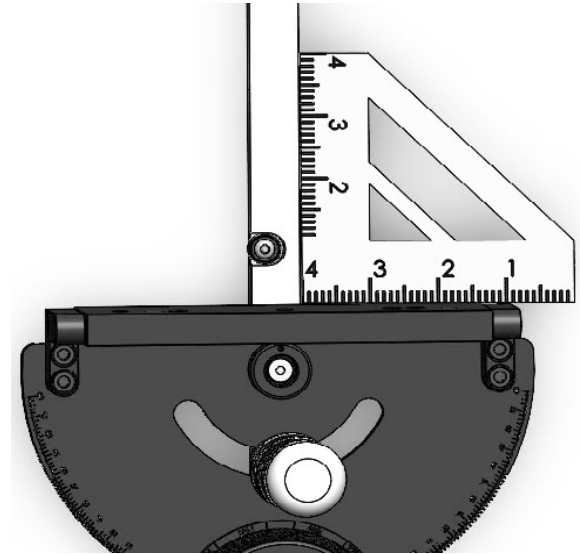

- Double-check your miter gauge for square after re-tightening the *Socket-Head Bolts*. Loosen the bolts and re-adjust as necessary until you are satisfied with the accuracy.
- When finished, replace the *Fence Assembly* onto the *Miter Gauge Body*.
- Verify that all fasteners adjusted during this process are tight.

## SQUARE THE MITER GAUGE WITH YOUR SAW

- Confirm the blade of your saw is parallel to the miter gauge slot. Adjust the saw trunnion or table as needed per the instructions provided by the manufacturer of your tool.

- Set your miter gauge for 0°. If needed, perform the steps in the previous section, **Square The Miter Angle** to ensure the face of the miter gauge is perpendicular to the miter bar when set for 0°.

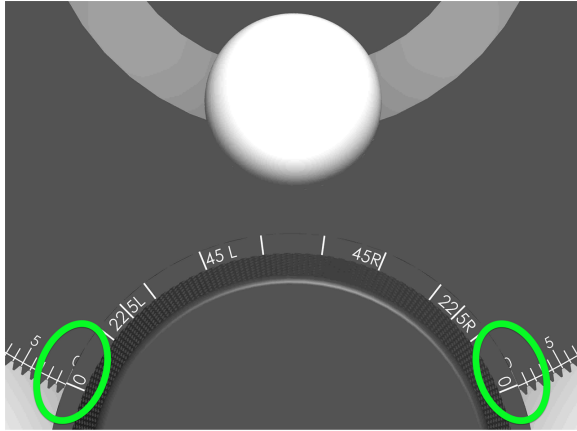

- With the power off and saw unplugged, raise the blade to full height.
- Use a precision reference square against the flat of the blade and your miter gauge to check for squareness.

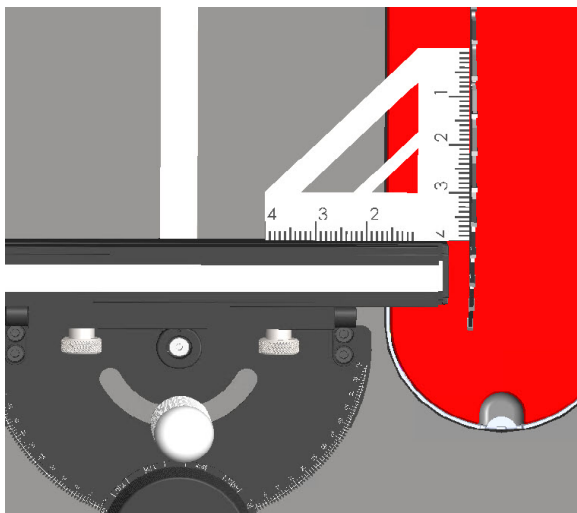

**! IMPORTANT:**  
Ensure that the contact between the reference square and the blade is limited to the flat of the blade. Avoid registering the square against saw blade teeth as this will skew the reading.

- If there is any gap or light between the square and the miter gauge or saw blade, one or a combination of the following could be the cause:
  - The saw blade is not parallel to the miter slot of the saw. To resolve this, adjust the saw trunnion or table as needed per the instructions provided by the manufacturer of your tool to bring the blade into parallelism with the miter gauge slot.
  - The Revolution Miter Gauge head is not perpendicular with its miter bar. To resolve this, refer to **SQUARE THE MITER ANGLE** on page 21 for instructions.

## ZERO THE FENCE RULER

The ruler attached to the *Fence Assembly* can be used in conjunction with the adjustable flip stop for convenient repeatable, fixed-length cuts without the hassle of juggling a separate tape measure.

### Procedure Summary:

Note that the built-in ruler begins at 1". The following procedure adds 1" of gap between the beginning of the ruler and blade. This is the offset necessary for ruler to be meaningful when making cuts. Also, this gap creates adequate clearance between the edge of the fence and your blade guard. Follow the steps below to complete this calibration.

- Loosen the silver, knurled *Fence Extension Release* by slightly by rotating it counter-clockwise.

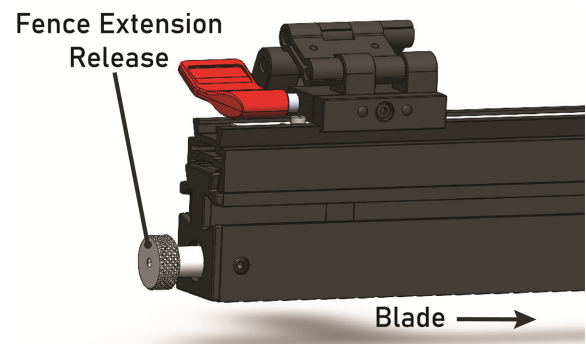

- The upper portion of the fence is now moveable. Push the upper portion of the fence to the right (toward the blade) to confirm that it is firmly against the stop, then re-tighten the *Fence*

*Extension Release.* The edges of the upper and lower extrusions that make up the *Fence Assembly* are now aligned.

- Loosen both silver, knurled *Thumbscrews* slightly. The *Fence Assembly* is now adjustable in relation to the *Miter Gauge Body*.

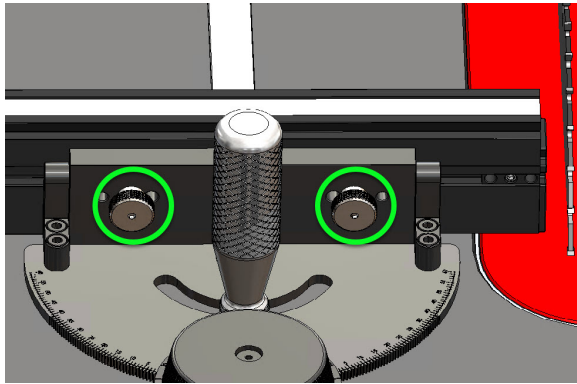

- With the machine turned off and unplugged, raise the saw blade to full height.
- Using a reliable ruler against the saw blade, align the 2" mark on your reference ruler with the 2" mark on the built-in ruler of the *Fence Assembly*. Adjust the position of the *Fence Assembly* left or right until this alignment is achieved.

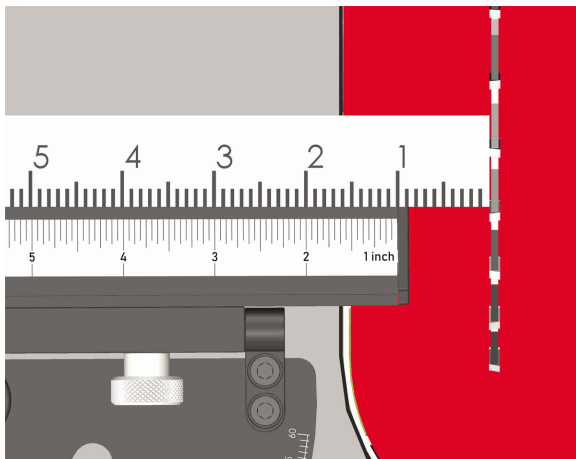

**! IMPORTANT:**

It is critical that this measurement is to the side of the blade teeth and not to flat of the steel surface of the blade. Teeth are typically wider than the steel of the blade making this detail important to achieving precision.

- Secure the *Fence Assembly* by tightening both silver, knurled *Thumbscrews* you loosened in step 3.

This calibration procedure is now complete. The built-in ruler can be relied upon for accurate cut lengths.

Read the ruler from the edge of the moveable flip stop carrier as shown in the illustration below.

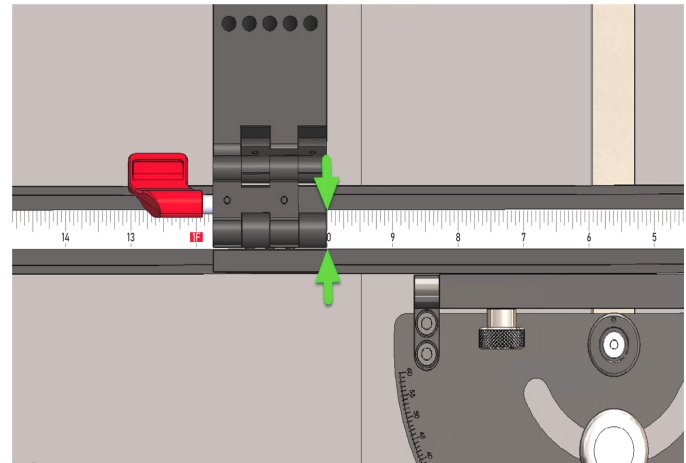

**i NOTE:**

The instructions in this procedure assume the miter gauge is currently configured for use in the table saw miter slot to the left of the blade. If you perform these calibration steps and later choose to change the setup of your miter gauge for use in the right side miter slot (see **Reversing the Fence Orientation** on page 14) or shift the fence position for any other reason, this calibration procedure will then need to be repeated.



## Time Saving Tip (optional)

If the *Fence Assembly* needs to be removed from the *Miter Gauge Body*, you can quickly restore it to the calibrated offset you just established without having to re-measure.

The procedure described below takes advantage of the set screws in the *Sliding Wedges* you used to **ATTACH AND ADJUST THE FENCE** on page 8. Tightening the set screws will fix the wedges in their place along the dovetail-shaped slot in the *Fence Assembly*.

1. Remove the silver, knurled *Thumbscrew* from the right side of the *Vertical Faceplate*. Take care not to bump the *Sliding Wedge* out of position as you draw the *Thumbscrew* out.

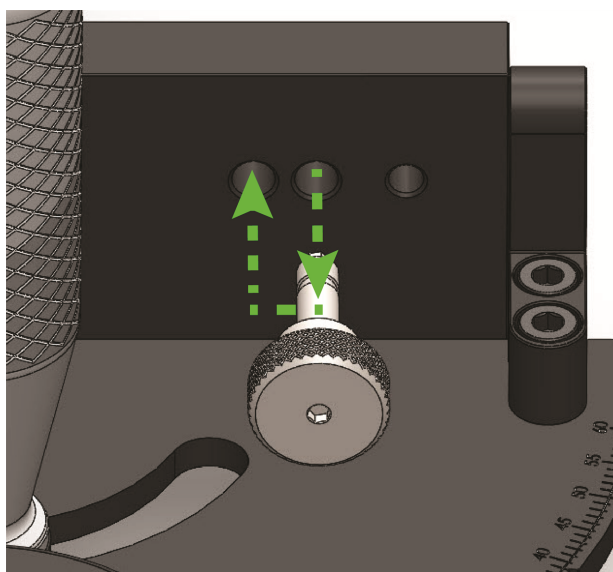

2. Gently insert the *Thumbscrew* you removed in Step 1 into the hole on the left as shown above. This hole on the *Vertical Faceplate* is aligned with a set screw in the *Sliding Wedge*. Use the hex tip the *Thumbscrew* to tighten the set screw. Turn the *Thumbscrew* clockwise until the set screw is snug.
3. Move the *Thumbscrew* back to the center hole and test that it can freely thread into the *Sliding Wedge*. If the *Thumbscrew* does not insert and thread freely, the *Sliding Wedge* may have been disturbed during the previous step. To fix this, loosen the set screw slightly and correct the position of the *Sliding Wedge*.
4. Tighten the *Thumbscrew* in the center hole.
5. Repeat steps 1-4 for the *Thumbscrew* and *Sliding Wedge* on the left side of the miter gauge.

In the future, should the *Fence Assembly* assembly need to be removed from the *Miter Gauge Body*, remove both *Thumbscrews* completely. Set the *Fence Assembly* and *Thumbscrews* aside.

To replace the *Fence Assembly*, align the center holes in the *Sliding Wedges* with the center holes on the *Vertical Faceplate* then secure it using the *Thumbscrews*.

## ADJUSTING PLAY IN THE GEAR CLUSTER

If after making a miter angle adjustment and before tightening the *Grip* you feel some excessive play between *Miter Gauge Body* and miter bar, this is an indication that mating between the gears in the internal gear cluster mechanism is loose. Use the instructions below to re-tighten the gear cluster.

Note the position of the indicator mark on the top surface of the bushing relative to 12 o'clock and 6 o'clock as you make changes to this adjustment. With the notch pointed at 12 o'clock, this adjustment is fully tightened, offering the least amount of play in the mechanism. With the notch pointed at 6 o'clock, this adjustment is fully loosened.

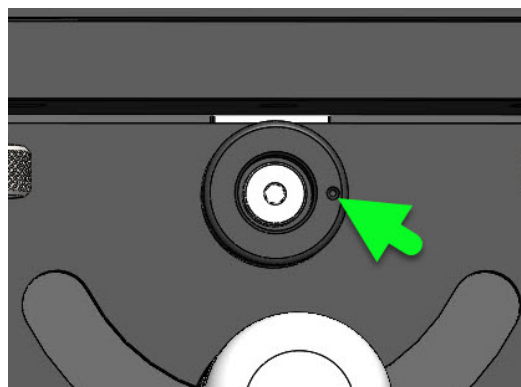

Adjustment steps:

1. Insert the included 3mm hex wrench into the silver screw shown in the illustration below. Turn it counter-clockwise to loosen it slightly. The adjustment bushing is now free to rotate.

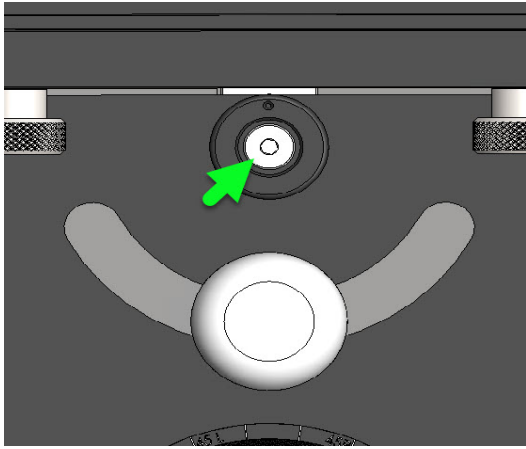

2. Rotate the adjustment bushing as needed. The gear mesh is tightest when the bushing marking is furthest from the handle (12 o'clock).

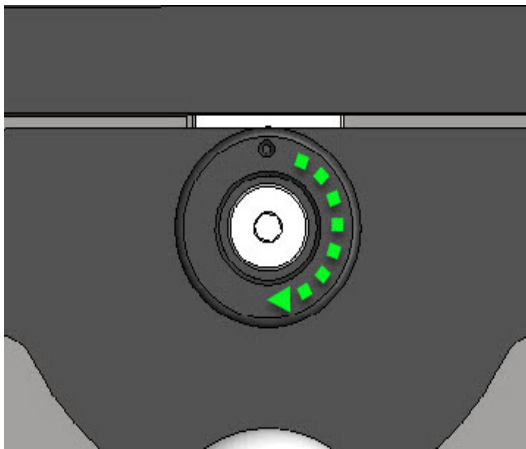

3. When you are satisfied with the adjustment, re-tighten the silver screw you loosened in step 1 using the included 3mm hex wrench. It is important that this screw is tight.

Small adjustments have a big impact, so make a small change, then test for play before making additional adjustments.

# TROUBLESHOOTING

PROBLEM	POSSIBLE CAUSE(S)	SOLUTION
Inaccurate angle cuts.	The angle cuts may not be precise due to the miter gauge being improperly aligned with the saw blade.	Refer to <b>CALIBRATION</b> on page 21 of this manual for detailed procedures to ensure blade alignment to the miter gauge and miter slot is correct.
Loose fit of miter bar in table slot.	The miter gauge may be loose and move around during use, causing inaccurate cuts.	See the chapter called <b>ADJUST THE MITER BAR FIT</b> on page 7 of this manual for detailed procedures to remedy this.
Workpiece is slipping.	The workpiece may slip out of place while cutting, causing inaccurate cuts.	Check the <i>Grip</i> on the miter gauge and confirm that it is sufficiently tightened before beginning cutting operations.  Also, ensure you are taking care to firmly hold your workpiece against the miter gauge fence during cutting operations.
Miter gauge is binding while moving material across the table.	The miter gauge may bind or become stuck during use preventing accurate cuts.	Check for any debris or sawdust that may be interfering with the movement of the miter gauge. Clean the miter gauge, saw table surface and the miter slots thoroughly before use.  In rare cases, there may be minor imperfections in the milling of the miter slot on your tool. Careful and judicious use of a fine metal file to reduce high spots on the sidewall of the miter slot may be required to remedy this issue.
Excessive play between miter gauge body and miter bar (rare).	The adjustment for the <i>Miter Angle Dial</i> gear cluster mechanism is too loose.	Your Revolution Miter Gauge is designed with an adjustment to correct this. See <b>ADJUSTING PLAY IN THE GEAR CLUSTER</b> on page 25 for instructions.
Tightening <i>Grip</i> is not effectively holding miter angle setting.	Missing washer between miter bar and miter plate.	Replace the missing washer. This M10 x 18mm OD x 1.5mm thick washer is available in the SawStop parts store at SawStop.com.
Fence face is loose or not perpendicular to table surface.	Missing washer between miter bar and miter plate.	Replace the missing washer. This M10 x 18mm OD x 1.5mm thick washer is available in the SawStop parts store at SawStop.com.

PROBLEM	POSSIBLE CAUSE(S)	SOLUTION
Slight visual misalignment between the markings on the <i>Miter Angle Dial</i> and the markings on the protractor of the miter gauge body.	Play has been adjusted in gear cluster (see page 25).	The miter gauge is still accurate and the misalignment is only visual. Always reference the nearest tactile feedback location for accurate cuts.
Miter angle does not hold true when load is applied to the far end of the fence.	The clamping force between <i>Grip</i> and miter gauge body is insufficient when pushing extremely heavy, rough sawn or wet workpieces that cause excess friction with the saw table.	<p>Solution 1: Orient the washer located between the <i>Grip</i> and the miter gauge body so the side of the washer with the slight burr is in contact with the miter gauge body.</p> <p>Solution 2: Add a small amount of grease to the threads on the <i>Grip</i> to increase the clamping force between the <i>Grip</i> and miter gauge body.</p>
Flip stop joints are too tight/too loose to fold.	The bolts holding the joints of the flip stop together are too tight or too loose.	Using the included 2mm hex wrench, tighten or loosen the bolts as needed. Small adjustments will have a large impact. Take care to not fully remove the bolts.
Flip stop comes off the fence when unlocked or is not holding position when fully locked.	The bolt that connects the two halves of the clamp assembly on the underside of the flip stop has shifted.	With the flip stop placed on the fence, adjust the bolt in center of the flip stop (in the middle on the smaller side). Tighten the bolt slowly while the flip stop is set to its most locked position. Check after small adjustments that the flip stop is now locked in place.
The <i>Miter Angle Dial</i> or <i>Fractional Degree Selector</i> is too tight/too loose to turn.	The ball plunger has shifted.	<p>Using a 3mm hex wrench (provided) tighten or loosen the ball plunger that contacts the dial or knob. The ball plunger can be accessed from the bottom of the miter bar. Small adjustments make a big difference.</p> <p>If the unit has been heavily used, the ball plunger may be slightly damaged. Replacement ball plunger is available in the SawStop parts store at <a href="http://SawStop.com">SawStop.com</a>.</p>



# NOTES



# NOTES



# NOTES





**SawStop, LLC**  
11555 SW Myslony St.  
Tualatin, OR 97062  
SawStop.com

Technical Support 503-582-9934 [service@sawstop.com](mailto:service@sawstop.com)  
Parts 503-486-6923 [parts@sawstop.com](mailto:parts@sawstop.com)  
Sales 503-595-2665 [sales@sawstop.com](mailto:sales@sawstop.com)

85-006132-00  
Rev C - Jan 2024