

SawStop[®]

Industrial Mobile Base

OWNER'S MANUAL

Model MB-IND-000



Warranty

SawStop warrants to the original retail purchaser of a new Industrial Mobile Base from an authorized SawStop distributor that the mobile base will be free from defects in material and workmanship for TWO YEARS from the date of purchase.

This warranty does not apply to defects arising from misuse, abuse, negligence, accidents, normal wear-and-tear, unauthorized repair or alteration, or lack of maintenance. This warranty is void if the mobile base or any portion of the mobile base is modified without the prior written permission of SawStop, LLC, or if the mobile base is located or has been used outside of the country where the authorized SawStop distributor from whom the mobile base was purchased resides.

Please contact SawStop to take advantage of this warranty. If SawStop determines the mobile base is defective in material or workmanship, and not due to misuse, abuse, negligence, accidents, normal wear-and-tear, unauthorized repair or alteration, or lack of maintenance, then SawStop will, at its expense and upon proof of purchase, send replacement parts to the original retail purchaser necessary to cure the defect. Alternatively, SawStop will repair the mobile base provided it is returned to SawStop, shipping prepaid, with proof of purchase and within the warranty period.

SawStop disclaims any and all other express or implied warranties, including merchantability and fitness for a particular purpose. SawStop shall not be liable for death, injuries to persons or property, or incidental, consequential, contingent or special damages arising from the use of the mobile base.

This warranty gives you specific legal rights. You may have other rights which, in the United States, vary from state to state.

Safety

1. Never place fingers, toes or other body parts under the mobile base. The base may suddenly lower on you and cause a severe injury.
2. Do not attempt to use or move the saw on an inclined surface. The saw is very heavy and difficult to stop on an inclined surface. Attempting to use or move the saw on an inclined surface could result in a severe injury.
3. Make sure the saw is fully lowered to the ground and stable before operating the saw. Otherwise, the saw could move unexpectedly and cause a severe injury.
4. Do not raise the saw higher than necessary to move it. Instead, raise the saw only enough to provide sufficient ground clearance.
5. Be sure to unplug or disconnect the saw from power before moving or repositioning it. The main power cord or the power outlet could be damaged if the saw is not disconnected from power before moving it.

How to Place the Saw in the Mobile Base

Before placing the saw on the mobile base, it is important to rotate the rear hold-down bracket back as far as possible and to rotate the front hold-down bracket forward as far as possible (see Fig. 1). To safely place the saw into the mobile base, you will need at least four people to lift the saw off the floor and then lower it onto the mobile base. Have one person lift each corner of the cast iron table top. If your saw has an extension table, have the two people on the right side of the saw lift on the extension rails near the outer corner of the cast iron extension wing, not at the end of the extension table.

If a fifth person is available, it may be easier to have four people lift the saw and the fifth person slide the base under the saw.

Make sure the mobile base is centered underneath the table saw and that the foot pedal is in the front. The saw should sit on the two “straps” on the interior of the mobile base, and the front of the cabinet should be touching the inside of the front face of the mobile base frame (see Fig. 1).

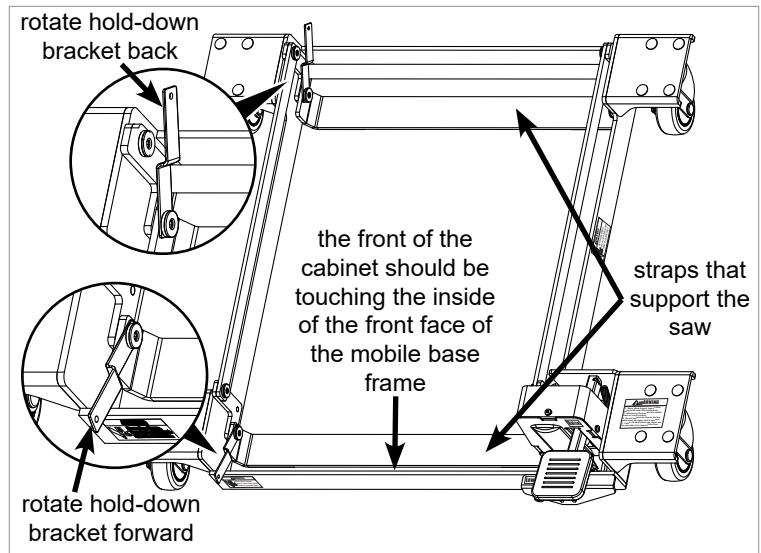

Fig. 1

Locate the two self-tapping screws and the two M4 x 12 x 1 washers. Some cabinet configurations will have pre-drilled holes for the self-tapping screws. If your saw cabinet does not have pre-drilled holes, or you are having difficulty aligning the holes, rotate the rear hold-down bracket until the top hole is over the flat face of the cabinet. Place one of the M4 x 12 x 1 washers over the end of one of the self-tapping screws and use a drill with a 1/4 inch hex drive bit to mount the rear hold-down bracket to the cabinet, as shown in Fig. 2a. There is no need to pre-drill a hole for the self-tapping screws, but be careful not to overtighten the screws or the threads in the cabinet may strip out. Now, rotate the front hold-down bracket until it is vertical and repeat the same procedure to mount it to the cabinet, as shown in Fig. 2b.

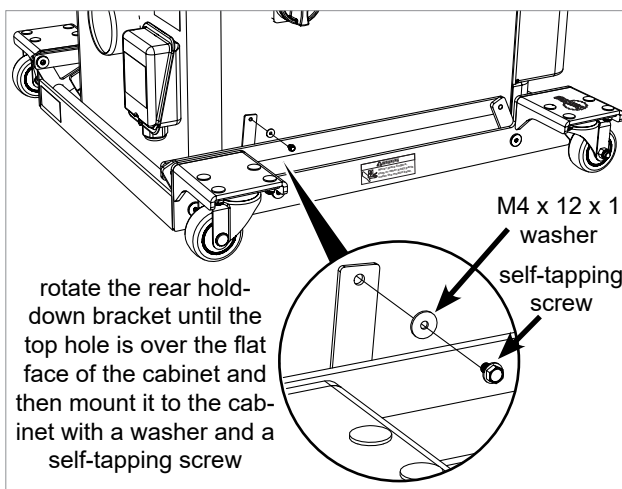

Fig. 2a

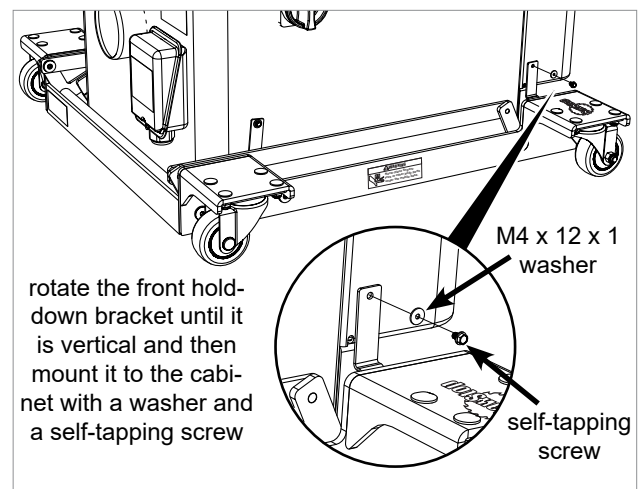

Fig. 2b

Your mobile base has been engineered to lift saws with or without extension tables. You do not need an additional arm extending out from the mobile base to support the extension table.

Using Your Mobile Base

1. To move your saw with the mobile base, step down on the foot pedal several times to raise the saw off the floor and onto the wheels (see Fig. 3). Do not raise the saw higher than necessary to move it. Instead, raise the saw only enough to provide sufficient ground clearance. Do not continue to step on the foot pedal once the upper limit is reached.
2. Push the saw to its desired location.
3. Step down on the left side of the release lever to lower the saw back to the floor (see Fig. 3).

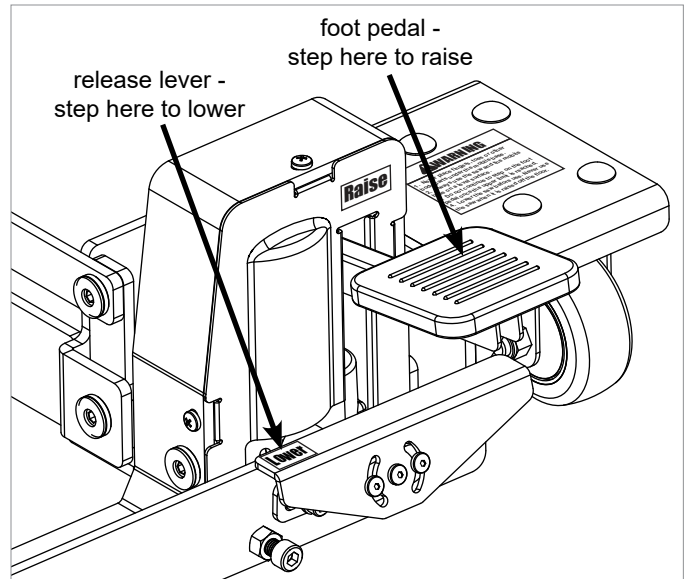

Fig. 3

Making Adjustments to Your Mobile Base

Your mobile base includes a release lever that allows you to adjust how fast the saw lowers. The lever should be adjusted so the saw gently descends back to the floor when the release lever is touching the release stop. If the saw descends too fast, descends too slowly, or does not descend at all, adjust the release lever as follows.

1. Loosen the three screws in the release lever with a 3 mm hex key (see Fig. 4). Do not remove the screws. Once the three screws are loose, the release lever will rotate around the center screw.

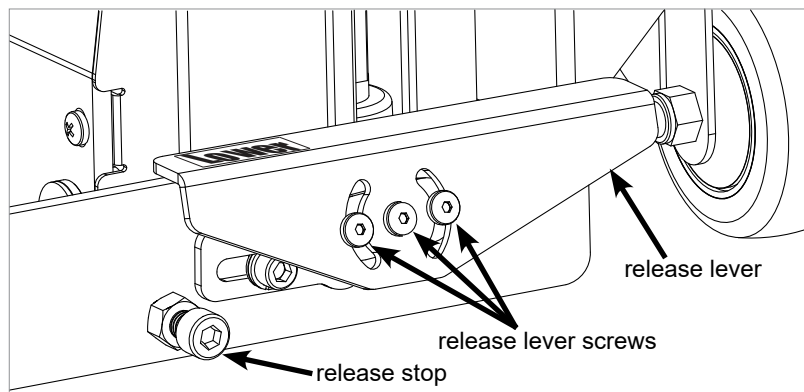

Fig. 4

Making Adjustments to Your Mobile Base

- To decrease the speed at which the saw lowers, rotate the release lever counter-clockwise a small amount (see Fig. 5). To increase the speed at which the saw lowers, rotate the release lever clockwise a small amount (see Fig. 6).

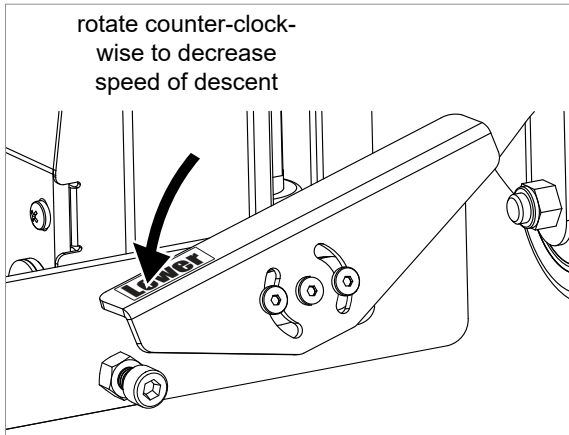

Fig. 5

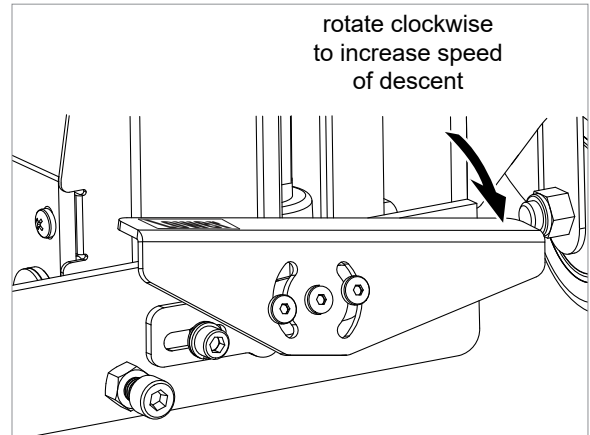

Fig. 6

- Once the release lever has been rotated, tighten all three screws and test how fast the saw lowers to the floor. If necessary, repeat steps 1-3 until the release operates as desired. If you have adjusted the release lever to the end of its adjustment range and your saw still descends too quickly or too slowly, proceed to steps 4-7. Otherwise, no additional adjustment is needed and you can skip steps 4-7.

Perform the following steps only if necessary after following steps 1-3.

- Remove the three screws in the release lever.
- Slide the release lever off the hexagonal shaft on which it is mounted.
- After removing the release lever, you will see a release adjustment plate (see Fig. 7). That plate has a hole with 12 notches. To decrease the speed at which the saw lowers, slide the adjustment plate off the hexagonal shaft and rotate the plate counter-clockwise one notch ($\frac{1}{12}$ th of a turn) before sliding it back onto the shaft. To increase the speed at which the saw lowers, slide the adjustment plate off the hexagonal shaft and rotate the plate clockwise one notch ($\frac{1}{12}$ th of a turn) before sliding it back onto the shaft.
- Reinstall the release lever on the hexagonal shaft, and screw in and fully tighten the three release lever screws. Test the speed at which the saw lowers and repeat these steps if necessary.

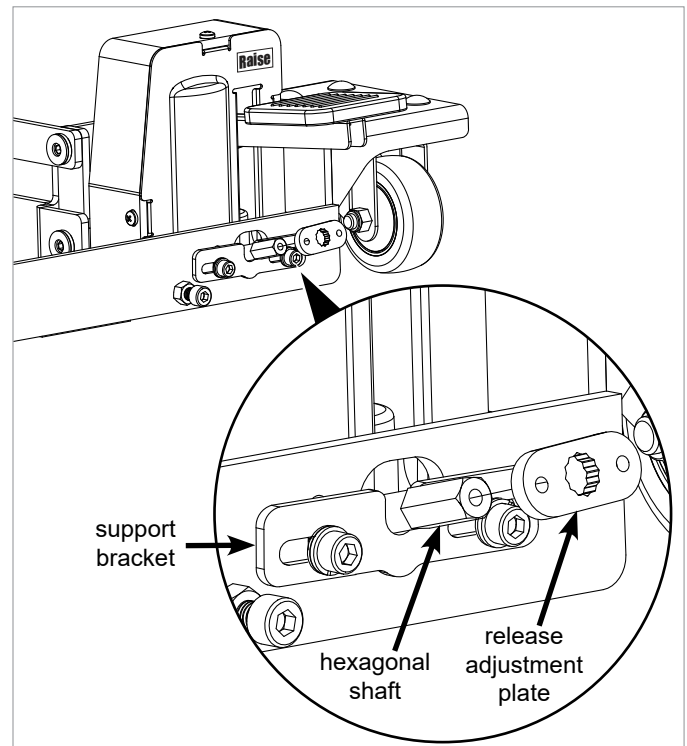
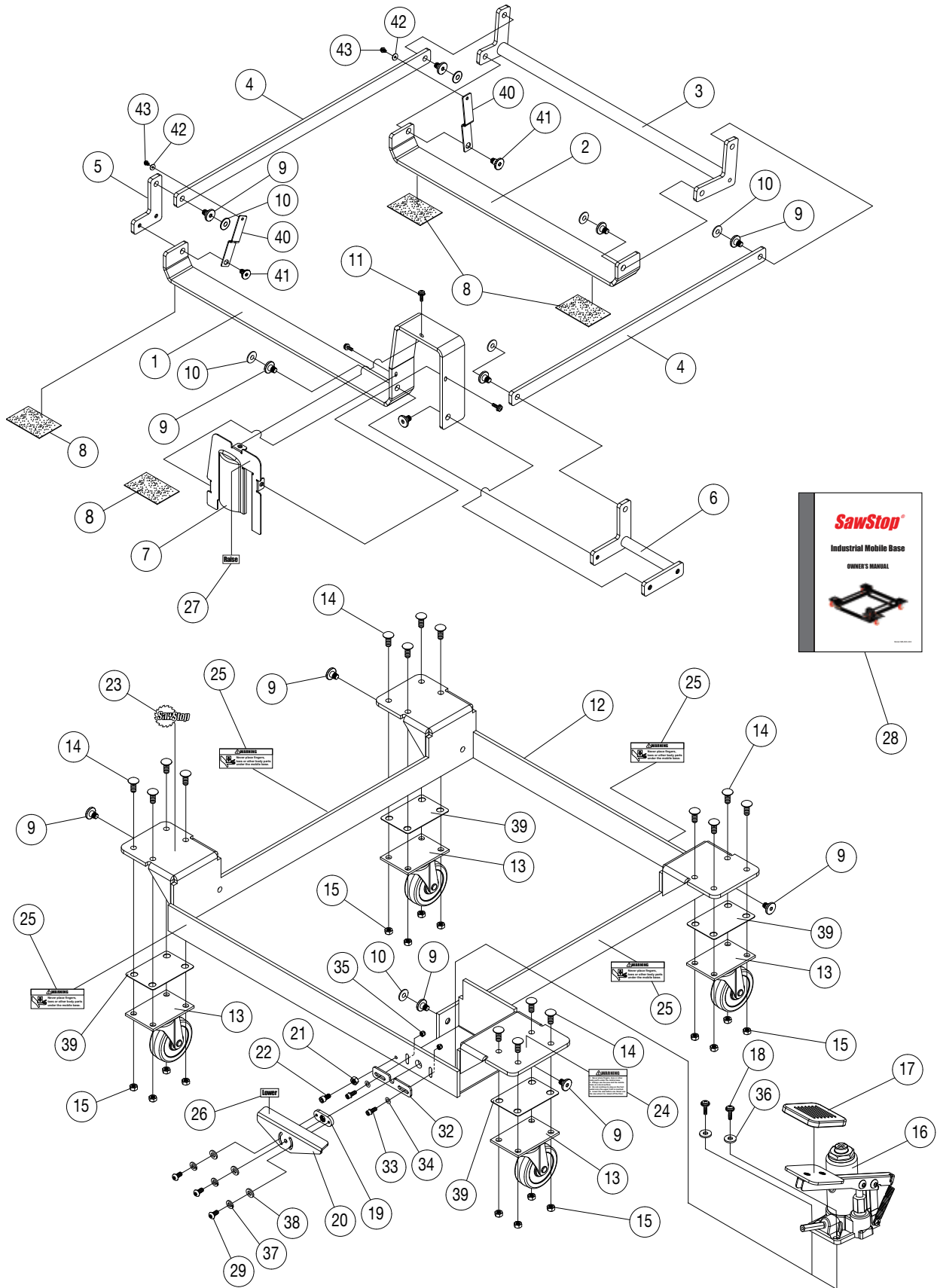

Fig. 7

Industrial Mobile Base Exploded View



Industrial Mobile Base Parts List

No.	Description	Part No.	Qty.
	Complete Mobile Base Assembly	MB-IND-000	1
1	Front Saw Strap	MB-IND-001	1
2	Rear Saw Strap	MB-IND-002	1
3	Shaft Linkage Assembly	MB-IND-003	1
4	Linkage Bar	MB-IND-004	2
5	Bell Link	MB-IND-005	1
6	Jack Linkage Assembly	MB-IND-006	1
7	Jack Cover	MB-IND-007	1
8	Adhesive Anti-Slip Tape	MB-IND-008	4
9	M8 x 1.25 x 15.7 Socket Shoulder Screw	MB-IND-009	12
10	Felt Bumper	MB-IND-010	7
11	M5 x 0.8 x 12 Button Head Philips Screw (includes one M5 lock washer and one M5 washer)	MB-IND-011	3
12	Frame	MB-IND-012	1
13	3" Caster Wheel	MB-IND-013	4
14	M8 x 1.25 x 20 Carriage Bolt	MB-IND-014	16
15	M8 x 1.25 Lock Nut	MB-IND-015	16
16	Hydraulic Jack (includes item 17)	MB-IND-016	1
17	Foot Pad	MB-IND-017	1
18	M6 x 1.0 x 12 Pan Head Philips Screw (includes one M6 lock washer)	MB-IND-018	2
19	Release Adjustment Plate	MB-IND-019	1
20	Release Pedal	MB-IND-020	1
21	M8 x 1.25 Hex Nut	MB-IND-021	1
22	M8 x 1.25 x 25 Socket Head Cap Screw	MB-IND-022	1
23	SawStop Logo Label	MB-IND-023	1
24	Main Warning Label	MB-IND-024	1
25	Finger/Toe Warning Label	MB-IND-025	4
26	Lower Label	MB-IND-026	1
27	Raise Label	MB-IND-027	1
28	Owner's Manual	MB-IND-028	1
29	M5 x 0.8 x 12 Button Head Socket Screw	MB-IND-029	3
32	Support Bracket	MB-IND-032	1
33	M6 x 1.0 x 20 Socket Head Cap Screw (includes M6 lock washer)	MB-IND-033	2
34	M6 x 12 x 1 Washer	MB-IND-034	2
35	M6 x 1.0 Lock Nut	MB-IND-035	2
36	M6 x 13 x 1 Washer	MB-IND-036	2
37	M5 Lock Washer	MB-IND-037	3
38	M5 x 12 x 1.25 Washer	MB-IND-038	3
39	Caster Spacer Plate	MB-IND-039	4
40	Hold-Down Bracket	MB-IND-040	2
41	M8 x 1.25 x 18 Shoulder Socket Screw (with felt adhesive pad)	MB-IND-041	2
42	M4 x 12 x 1 Washer	MB-IND-042	2
43	Self-Tapping Screw	MB-IND-043	2

Hydraulic Jack Maintenance

- Keep the jack clean and free from sawdust.
- Use SAE 30 oil to periodically lubricate the points shown in Fig. 9. To access the lubrication points, remove the three jack cover screws using a Philips head screwdriver (see Fig. 8) and then remove the jack cover.
- The jack must have the proper amount of hydraulic oil to function correctly. If the jack is not lifting or maintaining the weight of the saw properly you may need to remove the jack from the mobile base and add hydraulic oil as follows:
 1. Make sure the saw is lowered to the ground. Remove the center release lever screw shown in Fig. 8 using a 3 mm hex key. Remove the three jack cover screws, and the two jack mounting screws using a Philips screwdriver.
 2. Slide the release lever (with the attached release adjustment plate) off the hexagonal shaft. Remove the jack cover.
 3. Place a flat head screwdriver on top of the jack lifting piston (see Fig 9) and push the piston down as far as possible. Remove the jack by tilting the top forward and sliding the hexagonal shaft back out of the hole in the mobile base frame.
 4. Once the jack is removed, place it in an upright position and remove the extension spring. Completely depress the foot pedal. Remove the rubber filler plug shown in Fig. 9 by pulling it out with your fingers or prying it out with a flat head screwdriver. Add hydraulic jack oil so that the oil level is just to the bottom of the filler hole. Use only hydraulic jack oil. Replace the filler plug and extension spring and reinstall the jack by reversing the steps set forth above. Finally, verify that the support bracket is properly adjusted so that it is supporting the hexagonal shaft.

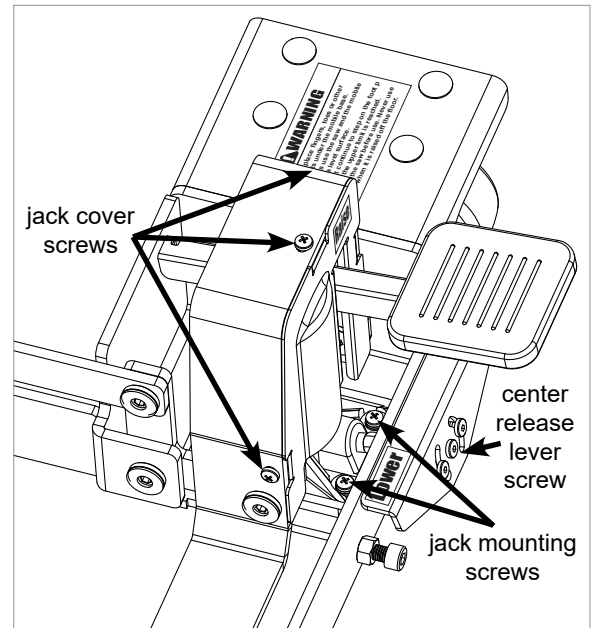

Fig. 8

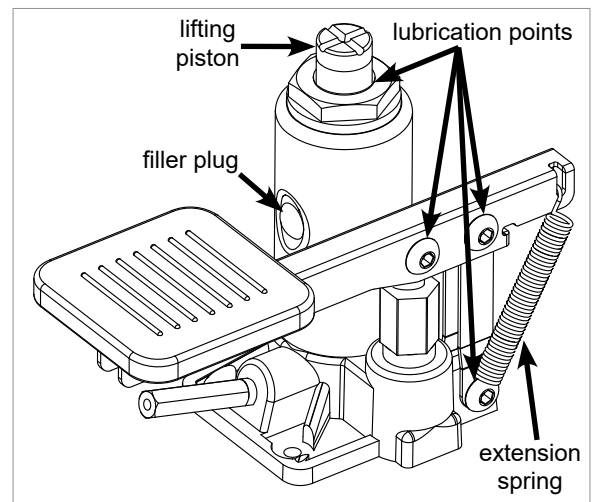

Fig. 9

SawStop, LLC
11555 SW Myslony St.
Tualatin, Oregon 97062
www.sawstop.com

Main Phone - (503) 570-3200
Service - (503) 582-9934
Fax - (503) 570-3303
Email: info@sawstop.com

Updates of this manual may be available at www.sawstop.com.

Copyright SawStop, LLC
All Rights Reserved.

M ICS 18 0004 00
May 2017