

# ***SawStop***<sup>®</sup>

## **T-Glide<sup>™</sup> Fence System- Industrial Series II**

### **OWNER'S MANUAL**

TGI2-FRT36A  
TGI2-FRT52A



## **Warranty**

SawStop warrants to the original retail purchaser of a new T-Glide Fence System - Industrial Series II from an authorized SawStop distributor that the fence system will be free from defects in material and workmanship for TWO YEARS from the date of purchase. SawStop warrants to the original retail purchaser of a refurbished, demonstration or floor model T-Glide Fence System - Industrial Series II from an authorized SawStop distributor that the fence system will be free from defects in material and workmanship for ONE YEAR from the date of purchase.

This warranty does not apply to defects arising from misuse, abuse, negligence, accidents, normal wear-and-tear, unauthorized repair or alteration, or lack of maintenance. This warranty is void if the fence system or any portion of the fence system is modified without the prior written permission of SawStop, LLC, or if the fence system is located or has been used outside of the country where the authorized SawStop distributor from whom the fence system was purchased resides.

Please contact SawStop to take advantage of this warranty. If SawStop determines the fence system is defective in material or workmanship, and not due to misuse, abuse, negligence, accidents, normal wear-and-tear, unauthorized repair or alteration, or lack of maintenance, then SawStop will, at its expense and upon proof of purchase, send replacement parts to the original retail purchaser necessary to cure the defect. Alternatively, SawStop will repair the fence system provided it is returned to SawStop, shipping prepaid, with proof of purchase and within the warranty period.

SawStop disclaims any and all other express or implied warranties, including merchantability and fitness for a particular purpose. SawStop shall not be liable for death, injuries to persons or property, or incidental, consequential, contingent or special damages arising from the use of the fence system.

This warranty gives you specific legal rights. You may have other rights which, in the United States, vary from state to state.

## **Safety**

1. You must install a rip fence before using your saw. Attempting to use the saw without a rip fence could result in serious personal injury.
2. Always use a rip fence when making rip cuts. Never perform a ripping operation freehand or a serious injury may result.
3. Always use a push stick or push block when your hand comes within 6" of the blade. Attempting to use the rip fence for narrow cuts without a push stick or push block could result in a serious injury.
4. Do not use the miter gauge when making rip cuts.
5. While making bevel cuts, use the fence only on the right side of the saw blade to prevent the blade from possibly contacting the fence. The brake will activate if the spinning saw blade comes into contact with the metal in the fence.

# Unpacking Your T-Glide Fence System

While unpacking your saw, verify that you have all the components shown below (Fig. 1) for your specific fence system. The T-Glide Fence System – Industrial Series II is available in either a 52" system or a 36" system. Although the components pictured below are from the 36" system, the components from the 52" system are similar.

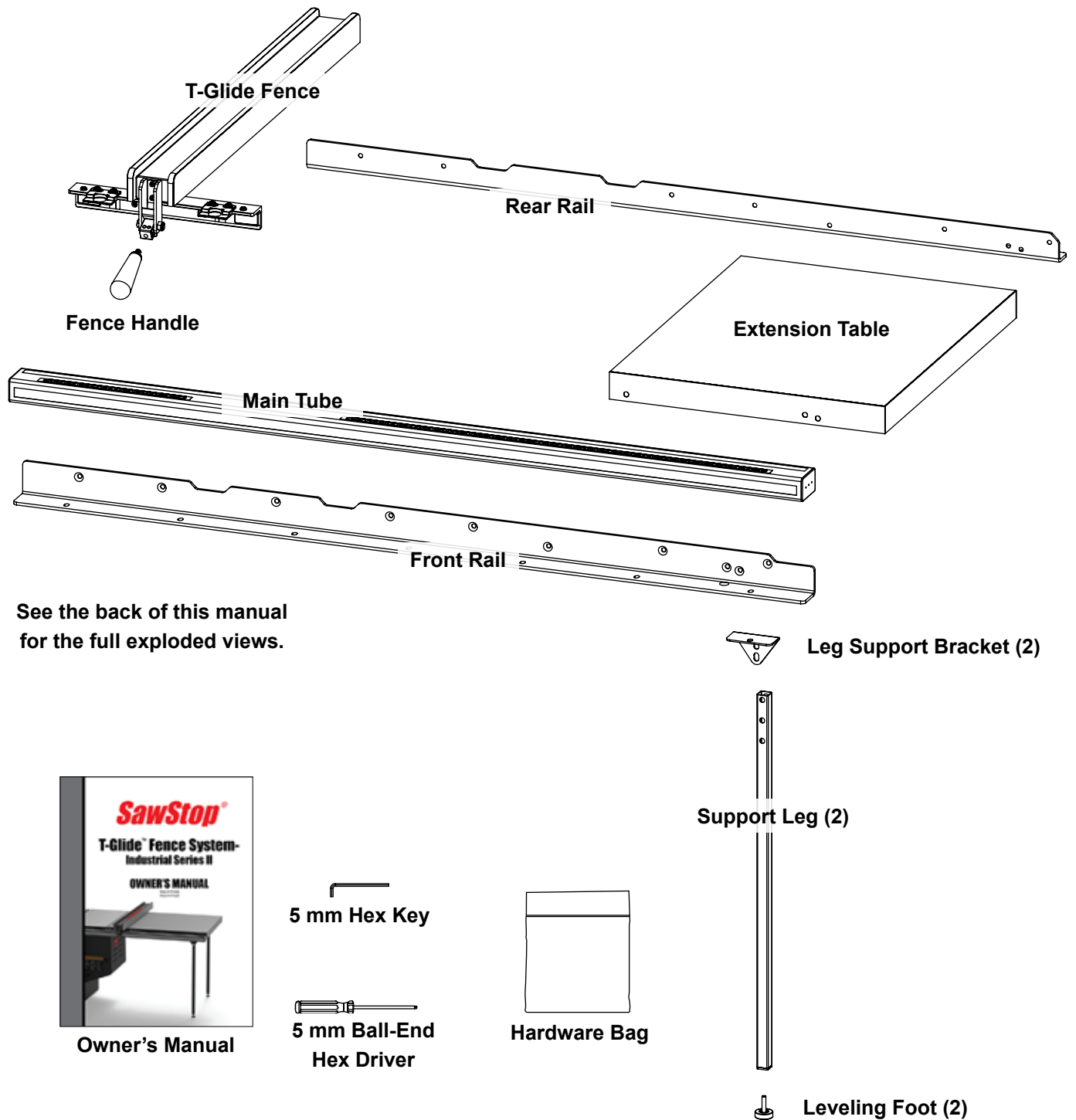

See the back of this manual for the full exploded views.

Fig. 1

## Installation

To install the rails, extension table, and fence you will need the following tools:

5 mm hex driver and 5 mm hex key (included)

6 mm hex key

13 mm and two 17 mm wrenches (or adjustable wrench)

Combination square

Phillips head screwdriver

Straight edge

**NOTE:** To see how all the components fit together, see the exploded views located in the back of this manual. The callout numbers in the image figures correspond with the exploded views.

**Front Rail:** The first step to install the fence is to attach the front rail to the table. The rails are shipped in the long cardboard box packaged with the main tube. The front rail (1) is the larger of the two and has 5 countersunk holes that are used to mount the rail to the front of the table. To mount the rail, begin by placing the rail on the floor next to the front of the saw. Lift the left end of the rail until the third hole from the left in the rail aligns with the center hole in the main table. Thread an M8 x 25 countersunk socket head bolt (6) into the threaded hole. (Fig. 2) Do not fully tighten.

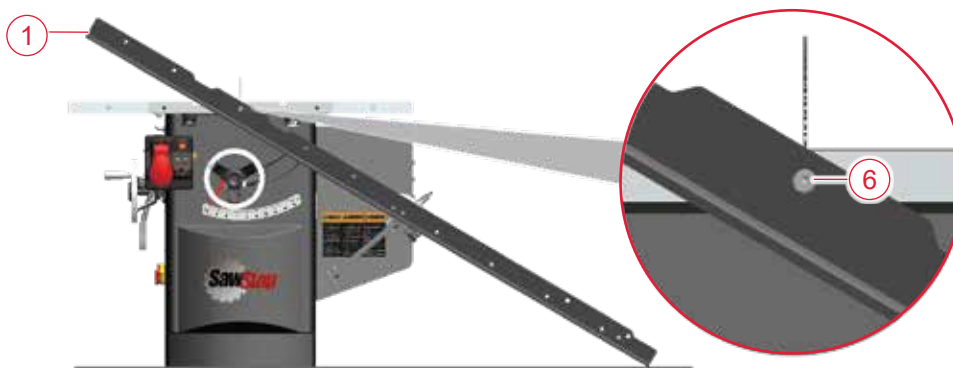

Fig. 2

Lift the right end of the rail until it's parallel with the table and thread two more M8 x 25 countersunk socket head bolts (6) into the other two threaded holes in the front of the main table (Fig. 3). Tighten the bolts using the 5 mm hex key.

Next, mount the front rail to the cast iron extension wings using two M8 x 35 countersunk socket head bolts (2) (the longer bolts), two M8 washers (3), two M8 lock washers (4) and two M8 hex nuts (5). Position the bolts through the front rail and the extension table, then install the washer, lock washer and nut (in that order) on the end of the bolt (Fig. 3). The holes in the extension wings are not threaded and are slightly larger than the bolts they receive. If necessary, use the rail to pull the wings up or down slightly until the wings are flush with the table. Use a 5 mm hex key and a 13 mm wrench to tighten the nuts, to secure the wings in place.

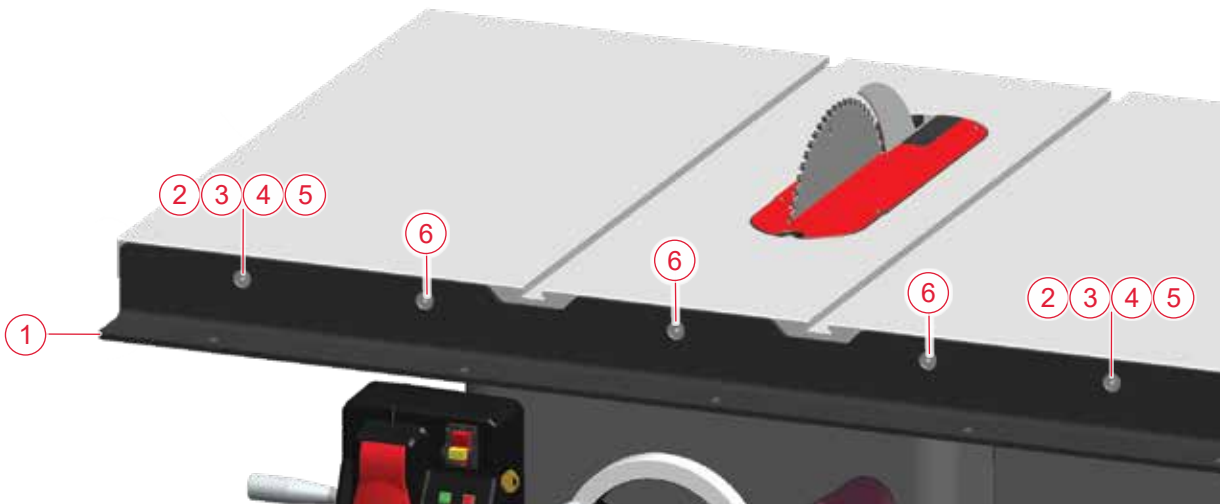

Fig. 3

**Rear Rail:** You install the rear rail (9) like you installed the front rail, except that you will leave the bolts for the rear rail a little loose until you install the extension table; it may be difficult to position the extension table between the rails if both rails are tightened too much. The rear rail is attached to the main table by two M8 x 25 (6) countersunk socket head bolts (Fig. 4). Position the rear rail along the back of the table with the cut-outs at the top of the rail centered on the miter gauge slots in the table. Thread the bolts into the holes and hand-tighten.

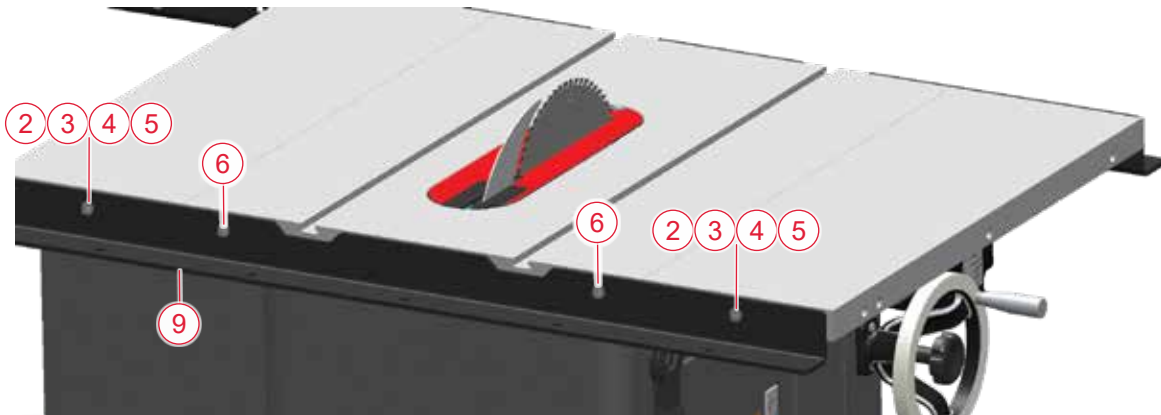

Fig. 4

Mount the rear rail to each extension wing using two M8 x 35 (2) countersunk socket head bolts (the longer bolts), two M8 washers (3), two M8 lock washers (4) and two M8 hex nuts (5) for each of the holes, as shown (Fig. 4).

**Leg Support Brackets:** Locate the two leg support brackets (20) and align them to the underside of each rail (Fig. 5). Insert two M8x20 countersunk socket head bolts (21) through the top of the rails. On the underside of each bracket, place an M8 washer (14), an M8 lock washer and an M8 hex nut (16). Hand-tighten the nuts.

Once mounted, the brackets should create a shelf for the table to rest on (Fig. 6).

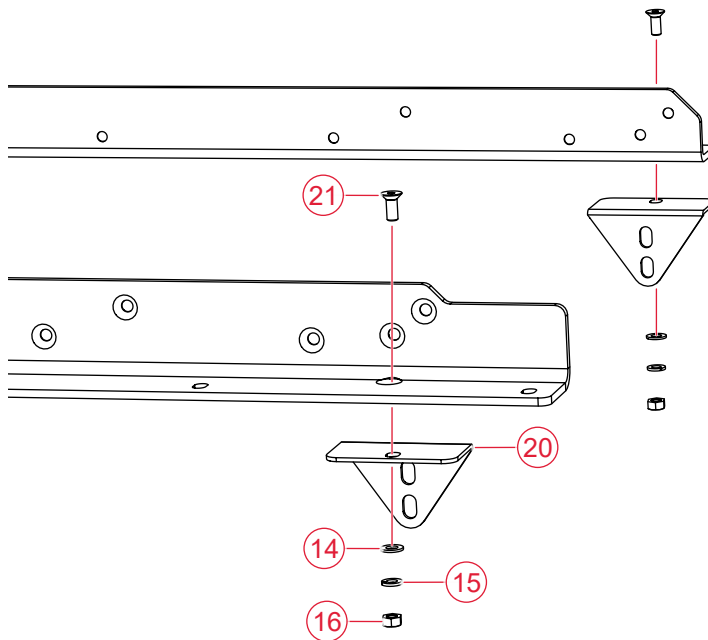

Fig. 5



Fig. 6

**Extension Table Adjustment Bracket, 36 and 52 Inch Fence Systems:** If you have a wing that has the threaded hole as shown in Fig. 7, use the adjustment bracket. If you have a wing that does **not** have the threaded hole, use the supplemental hardware--skip to the *Supplemental Mounting Kit* section on the next page. The extension table works with either the adjustment bracket or the supplemental mounting kit.

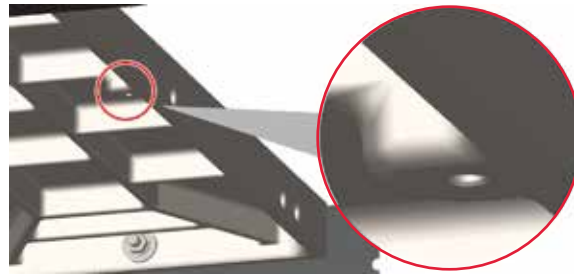

Fig. 7

The adjustment bracket (32) is included in the hardware bag and comes with the adjustment screw (31) pre-installed. Slide the adjustment bracket into position on the frame of the extension table; align with the two nuts embedded in the frame (Fig. 8). Attach using two M6 x18 socket head cap screws (30) and two M6 lock washers (33).

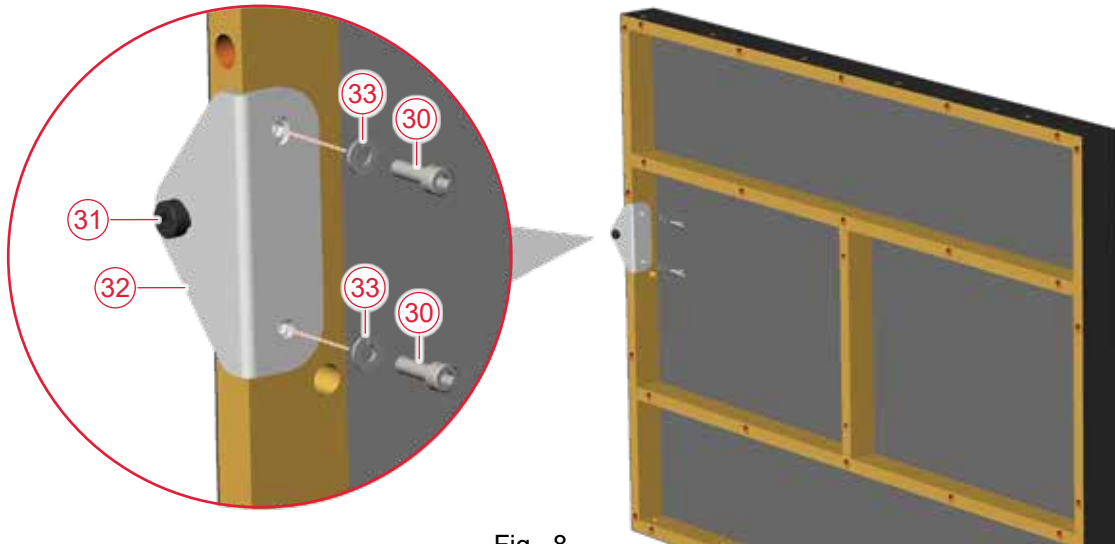

Fig. 8

Place the extension table between the rails, with the adjustment bracket closest to the saw, and then slide the table towards the extension wing (Fig. 9). Be careful when positioning the extension table as it is not secured to the rails and could fall.

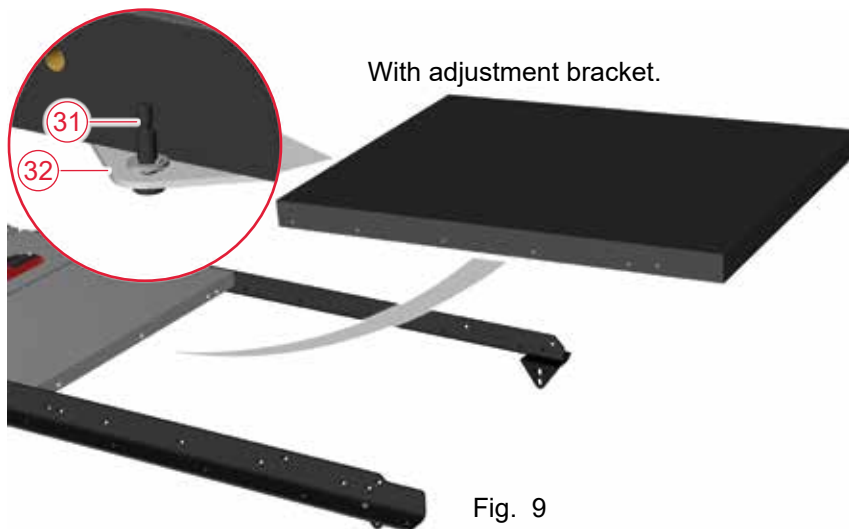

Fig. 9

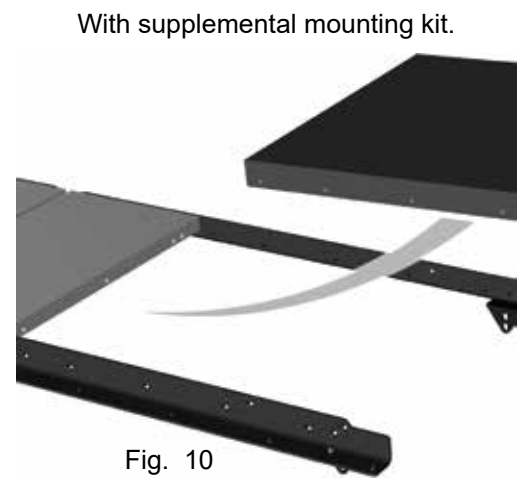

Fig. 10

Tilt the extension table slightly so that the adjustment bracket can fit under the edge of the extension wing. Position the extension table so that the end of the adjustment screw aligns with the corresponding threaded hole (Fig. 7) in the bottom of the extension wing. With the weight of the extension table still supported, turn the adjustment screw with a 5 mm hex key until the extension table is level and flush with the extension wing.

**Supplemental Mounting Kit.** (If your extension table uses the adjustment bracket, you can skip this section.) The supplemental mounting kit is included in the hardware bag. The extension table contains a through-hole in the center of the left side of the frame that aligns with a matching hole in the center of the edge of the right extension wing. Place the extension table between the rails (Fig. 10). Install the M8 x 45 socket head bolt (A) and D-washer (B) through the hole in the extension table. (Fig. 11) The bolt should extend through the hole in the extension wing. Make sure the flat edge of the D-washer faces upward. Install an M8 x 23 x 2 washer (C), and an M8 x 1.25 hex nut (D) on the end of the bolt and hand-tighten, do not completely tighten at this time.

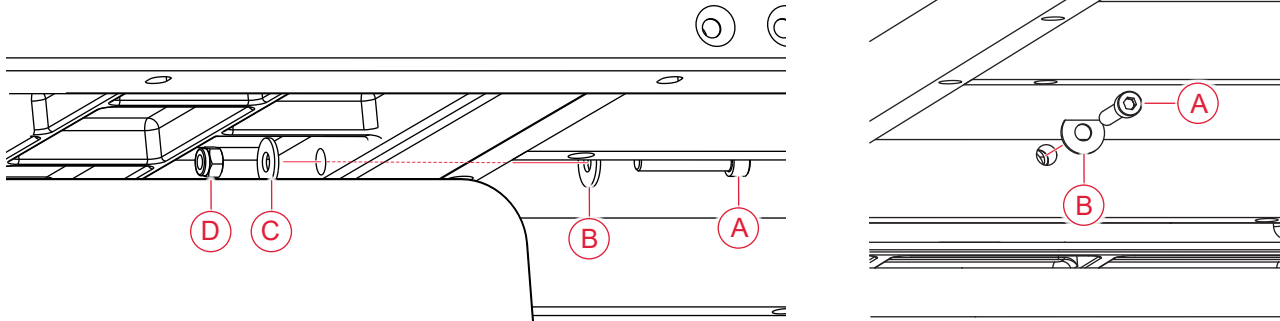

Fig. 11

**Extension Table, 36 Inch Fence System:** The extension table mounts to rails with bolts that pass through holes in the rails and extension table. Insert an M8 x 40 countersunk socket head bolt (17) through the holes in both the front and rear rails, closest to the wing (Fig. 12).

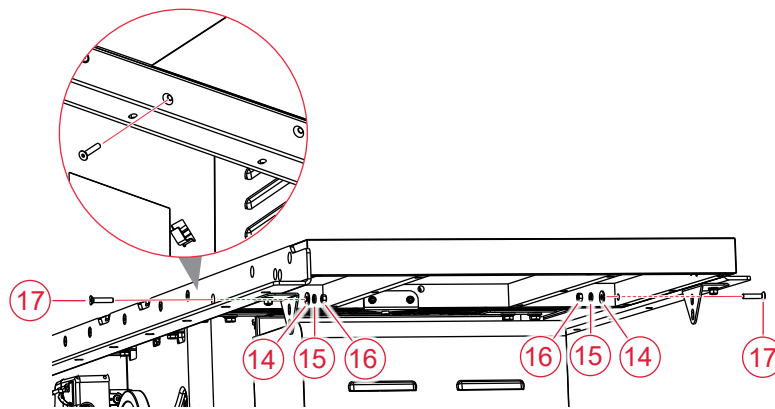

Fig. 12

**Extension Table, 52 Inch Fence System:** Insert an M8 x 40 countersunk socket head bolt (17) through each of the two holes in both the front and rear rails, closest to the wing (Fig. 13).

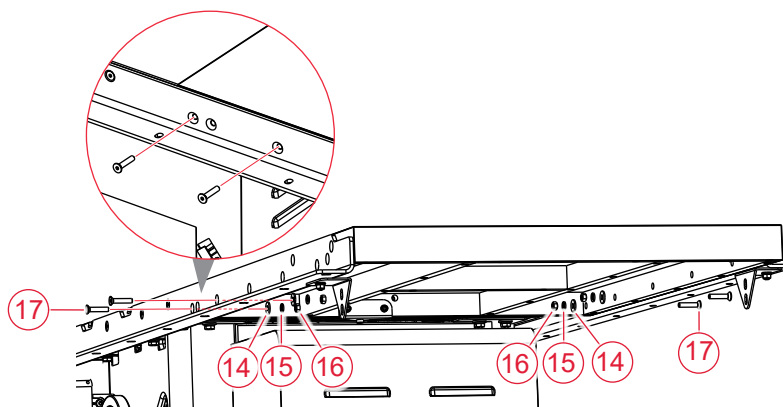

Fig. 13

Place an M8 washer (14), an M8 lock washer (15) and an M8 hex nut (16) on the threaded end of each bolt. Hand-tighten the nuts; do not fully tighten them. **Do not insert bolts through the outermost holes in the front and rear rails at this time.**

**Support Legs, 36 and 52 Inch Fence Systems:** Begin by installing the leveling foot (19) in the bottom of each support leg (18). First, thread an M8 nut (16) onto the threaded shaft of the foot as close to the rubber base as possible. Next, thread the foot into the bottom of the support leg as far as possible (Fig. 14).

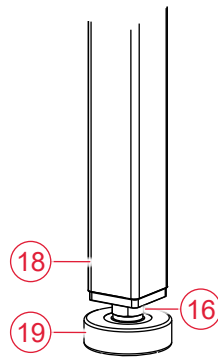

Fig. 14

The support legs attach to the outer ends of the rails and extension table with M8 x 65 countersunk socket head bolts (22). Align the top hole in one support leg with the second-outermost hole in the front rail, and the top hole in the second support leg with the outermost hole in the rear rail. Make sure the legs are positioned against the inside of the extension table. Insert M8 x 65 bolts (22) through the holes in each of the rails, extension table and each leg. Place an M8 washer (14) and an M8 lock washer (15) on the threaded end of each bolt and then thread an M8 hex nut (16) onto each bolt (Fig. 15). Hand-tighten the nuts; do not fully tighten them.

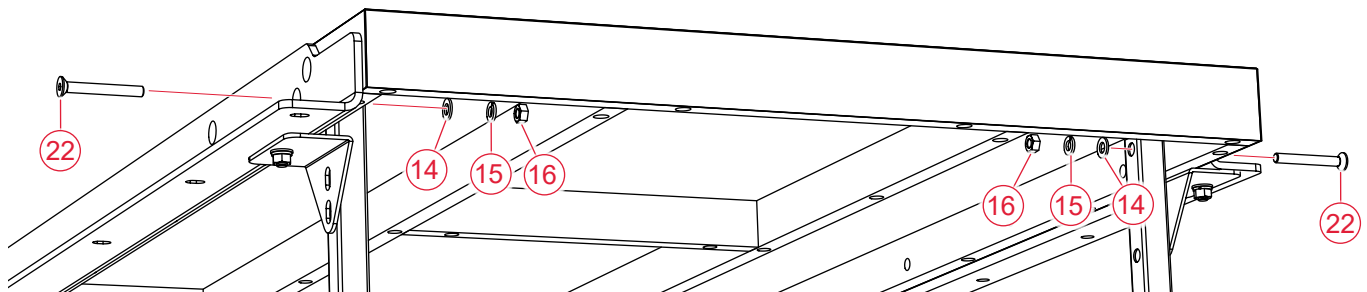

Fig. 15

Attach each support leg to the corresponding leg support bracket with an M10 x 45 hex head bolt (23), two M10 washers (24), and an M10 lock nut (25) (Fig. 16), and then fully tighten the bolts using two 17 mm wrenches.

NOTE: The leg support brackets align with different holes in the front and rear legs because the brackets are at different heights.

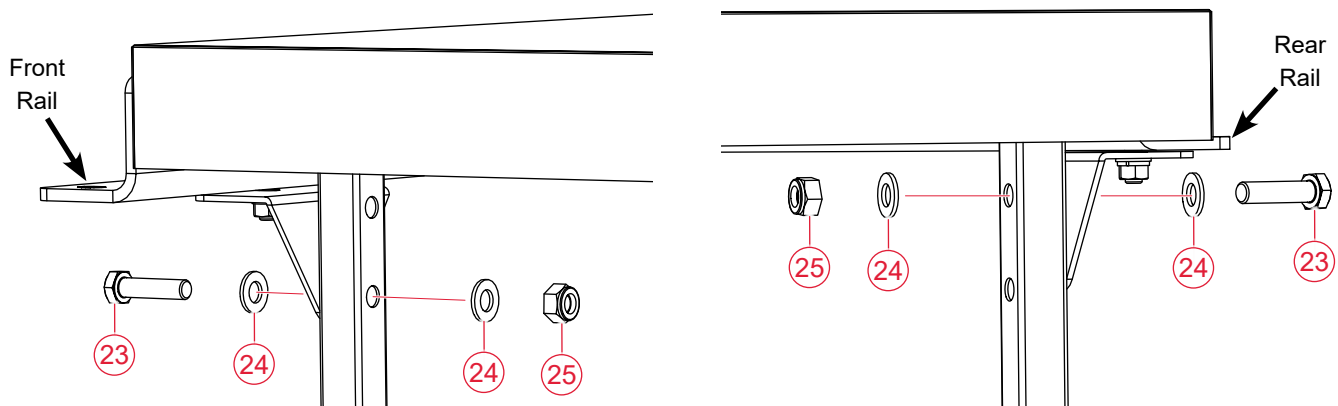

Fig. 16



**Extension Table, 36 Inch Fence System (cont.):** Insert an M8 x 40 countersunk socket head bolt (17) through the one remaining **front** rail hole and into the corresponding hole in the front edge of the extension table (Fig. 17). Place an M8 washer (14), an M8 lock washer (15) and an M8 hex nut (16) and hand-tighten.

Insert an M8 x 40 countersunk socket head bolt (17) through the **rear** rail and into the corresponding hole in the rear edge of the extension table. Place an M8 washer (14), an M8 lock washer (15) and an M8 hex nut (16) and hand-tighten.

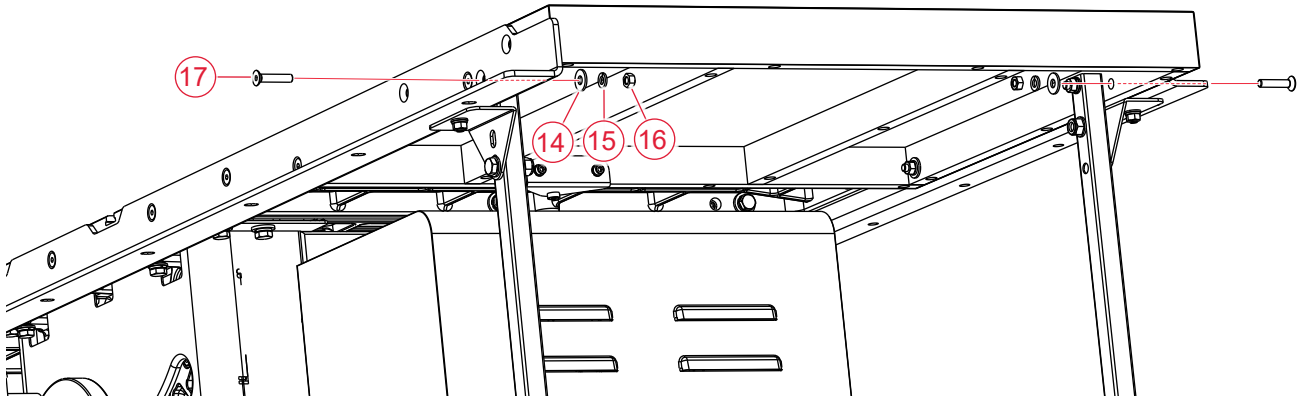

Fig. 17

**Extension Table, 52 Inch Fence System (cont.):** Insert M8 x 40 countersunk socket head bolts (17) through the three remaining **front** rail holes and into the corresponding holes in the front edge of the extension table (Fig. 18). Place an M8 washer (14), an M8 lock washer (15) and an M8 hex nut (16) on each bolt and hand-tighten.

Insert M8 x 40 countersunk socket head bolts (17) through the three remaining **rear** rail holes and into the corresponding holes in the front edge of the extension table. Place an M8 washer (14) and an M8 lock nut (16) on each bolt and hand-tighten.

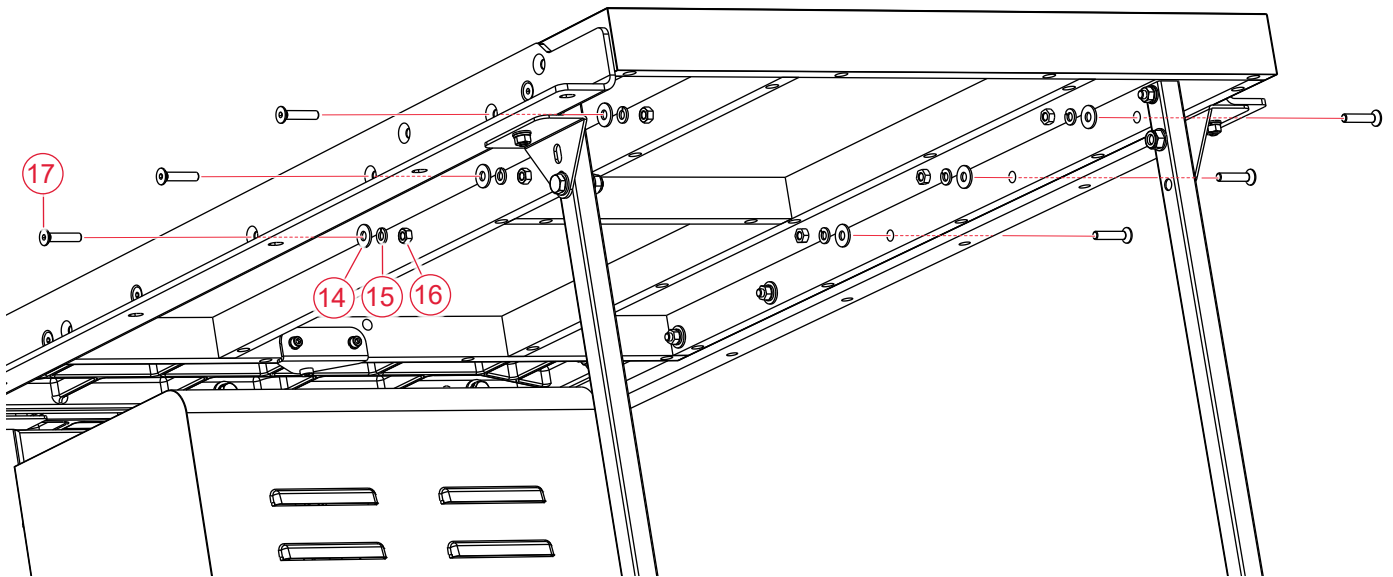
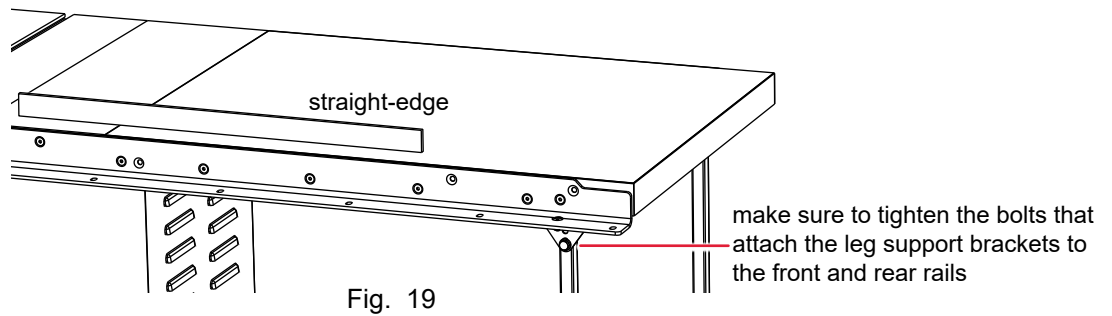
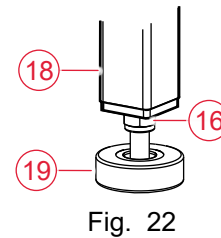
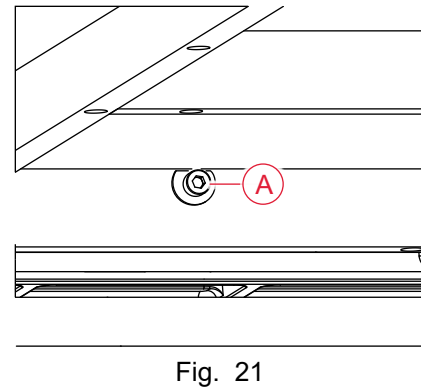
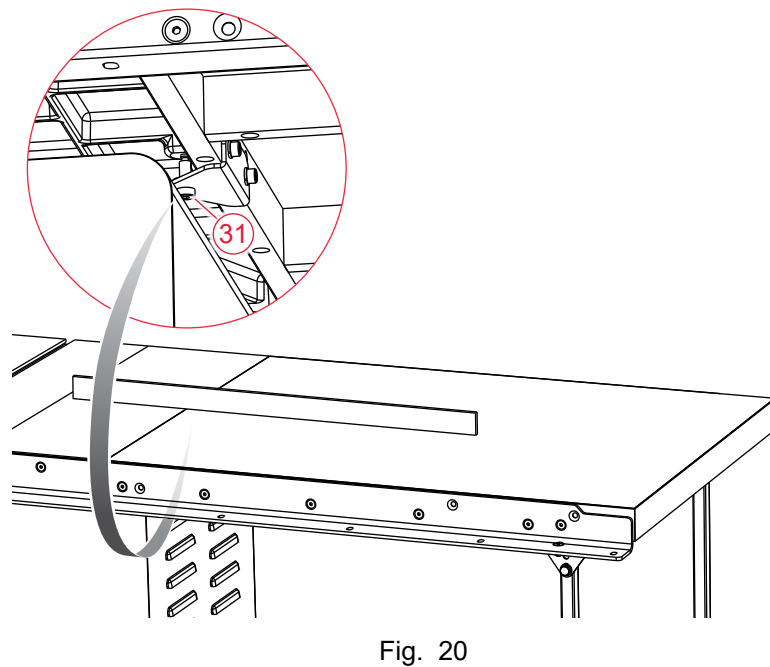

Fig. 18

**Alignment, 36 and 52 Inch Fence Systems:** Use a straight-edge to level the front edge of the extension table to the saw table (Fig. 19). You may have to pull up or push down on the extension table to level it. Once the front edge of the extension table is level, use a 5 mm hex key and a 13 mm wrench to fully tighten the nuts on the bolts along the front rail. Repeat the process to level the rear edge of the extension table. Also fully tighten the bolts that attach the leg support brackets to the front and rear rails.



Place the straight-edge on the middle of the table (Fig. 20), and then turn the screw (31) in the adjustment bracket with a 5 mm hex key to level the middle of the extension table. If using the supplemental mounting kit, push up or down on the middle of the table, and then tighten the socket head bolt (A) (Fig. 21).



Finally, adjust the position of the foot (19) on the bottom of both support legs (18) to ensure the legs are in solid contact with the ground. Tighten the nut (16) (Fig. 22).

**Main Tube:** The main tube (8) is installed on the front rail using the M8 x 16 hex head bolts with captured washers (7). Position the tube on the front rail with the rulers facing up and the 12" ruler on the left side. The tube and rail can be slick, so be careful that the tube does not fall off the rail. Align the holes in the rail with the holes in the bottom of the tube. Thread the M8 x 16 hex head bolts through the rail and into the threaded holes in the bottom of the tube (Fig. 23) and hand-tighten.

Note: the hardware bag includes enough hardware to mount the 52" tube. If you have a 36" assembly, disregard the extra hardware.

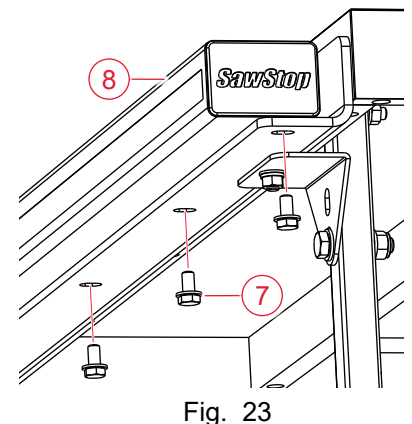

The holes in the bottom of the front rail are oversized to allow the position of the tube on the rail to be adjusted. To set the tube in the correct position, pull the tube away from the cast-iron table as far as possible. Next, place the fence on the tube with the fence glide bracket resting on the upper rear edge of the tube. Position the fence so that it is near the left end of the tube and the front glide plates (10) are in contact with the rear surface of the main tube (Fig. 24).

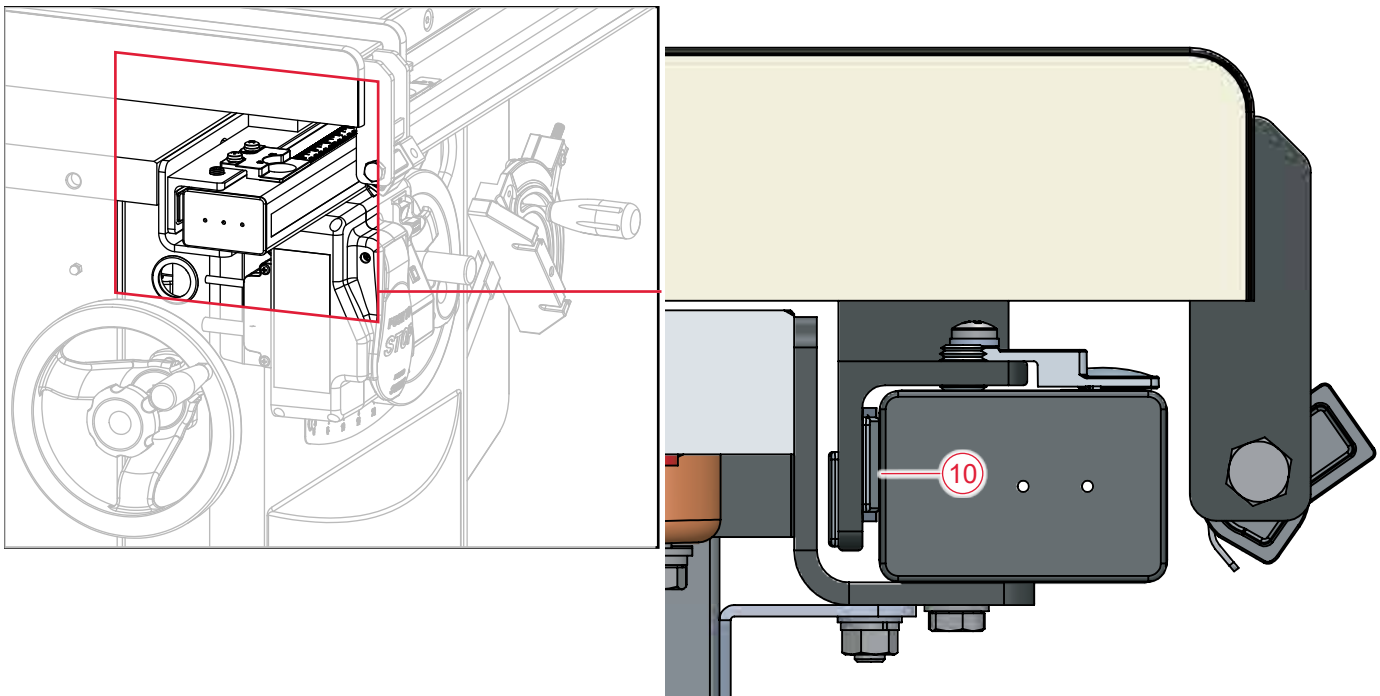

Fig. 24

Next, attach the fence handle to the fence by threading the handle into the cam lock (Fig. 25). Press down on the fence handle to clamp the fence to the main tube (Fig. 26).

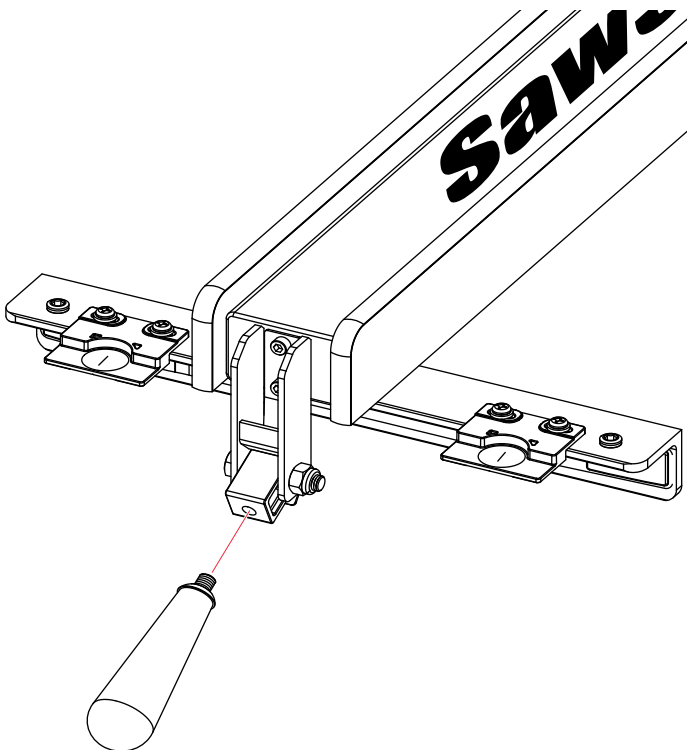

Fig. 25

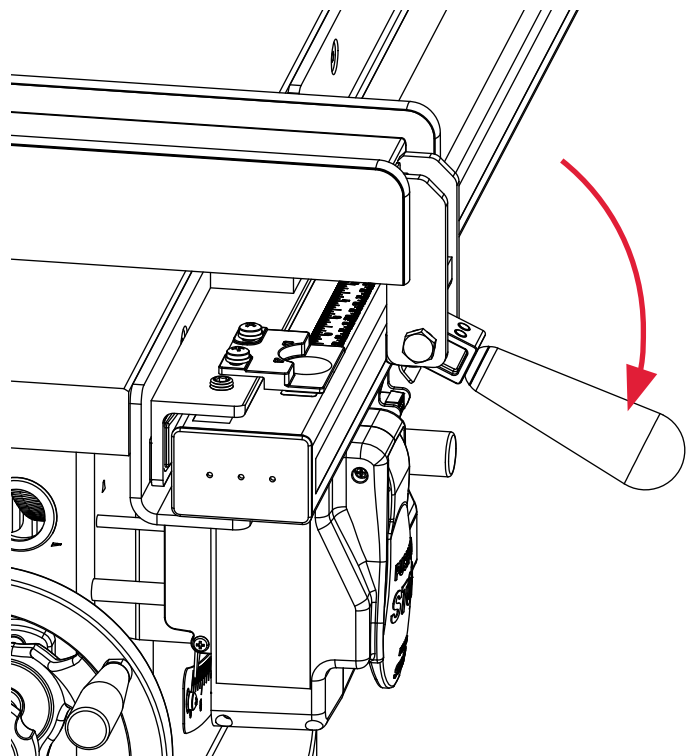

Fig. 26

**Locking Force:** If the fence is clamped but does not hold its position on the main tube, use a 5 mm hex key to turn both parallelism adjustment screws (11) clockwise an equal amount to increase the pressure. The screws are located on the back of the glide bracket (Fig. 27). If the handle requires too much force to clamp the fence to the main tube, turn the adjustment screws counter-clockwise to reduce the clamping force.

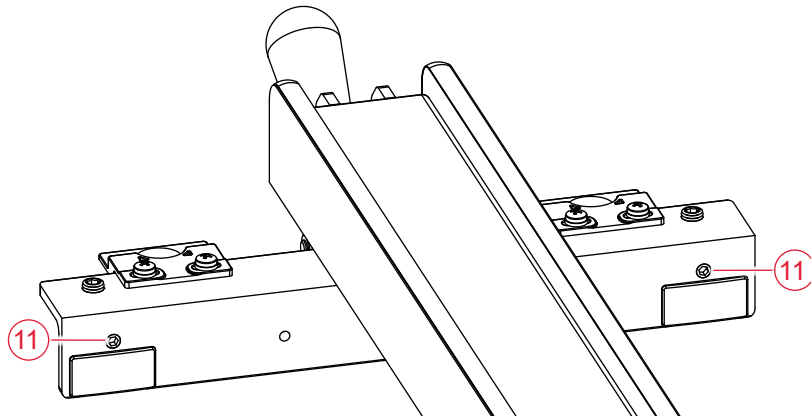

Fig. 27

**Glide Clearance:** Once the fence is correctly clamped to the main tube (8), adjust the position of the left end of the tube so that there is only a small gap (approximately 1/16") (A) between the front rail (1) and the rear glide plates (10) on the fence (Fig. 28). Tighten the left-most M8 x 16 hex head bolt (7) that mounts the tube to the front rail using a 13 mm wrench (Fig. 29).

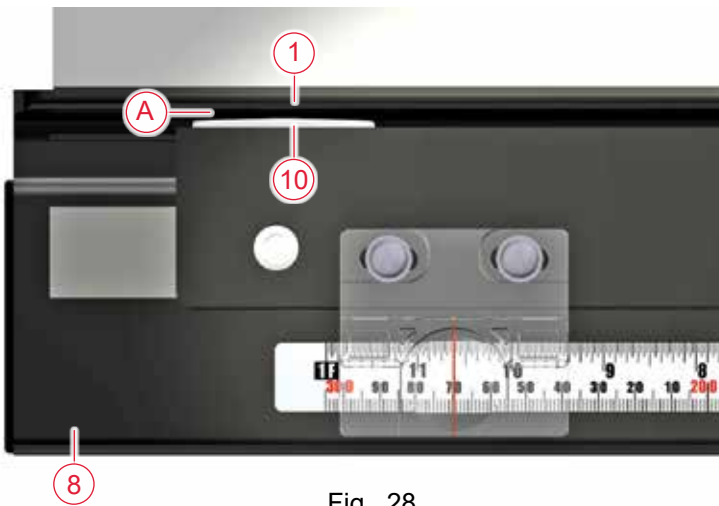

Fig. 28

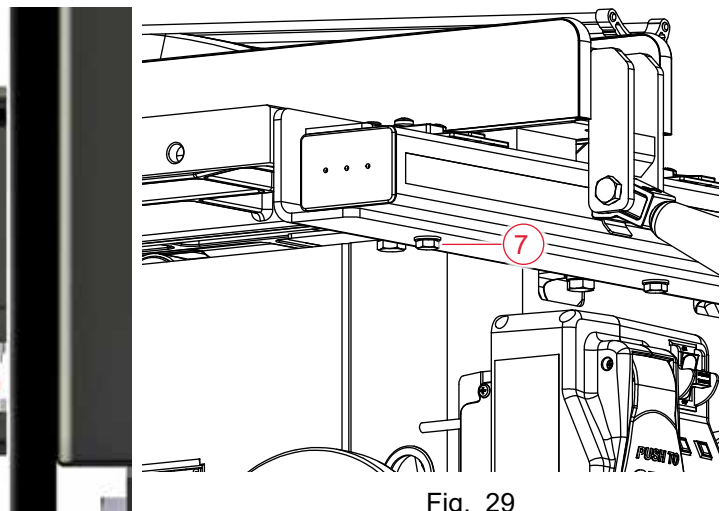

Fig. 29

Next, move the fence to the right end of the tube and repeat the preceding process. Tighten the right-most M8 bolt that mounts the tube to the front rail. Confirm that the left end of the tube is still correctly positioned by sliding the fence to the left end of the tube. If the gap between the tube and rail on the left end has changed, loosen the left-most bolt and readjust the position of the tube. Once both ends of the tube are adjusted correctly, tighten the remaining M8 x 16 hex head bolts to lock the tube to the front rail. The fence should now slide smoothly along the tube without binding and without excessive play when changing directions.

## Fence Adjustments

Although the fence is factory-adjusted to nominal settings, it is usually necessary to make final adjustments once your rails and extension table have been installed on the saw.

The fence allows you to precisely set the width of your rip cuts (cuts that are length-wise along the grain of the wood). The precise width of cut is shown by the position indicator lenses (12) on the front of the fence (Fig. 30). The lens on the left indicates the width of cut when the fence is on the left side of the blade. The lens on the right indicates the width of cut when the fence is on the right side of the blade. Each indicator lens is positioned above a ruler on the front tube. Each lens has a red cursor line that indicates the precise width of cut. To read the width of cut, look down at the cursor line. The mark on the ruler that is directly below the cursor line is the width of cut.

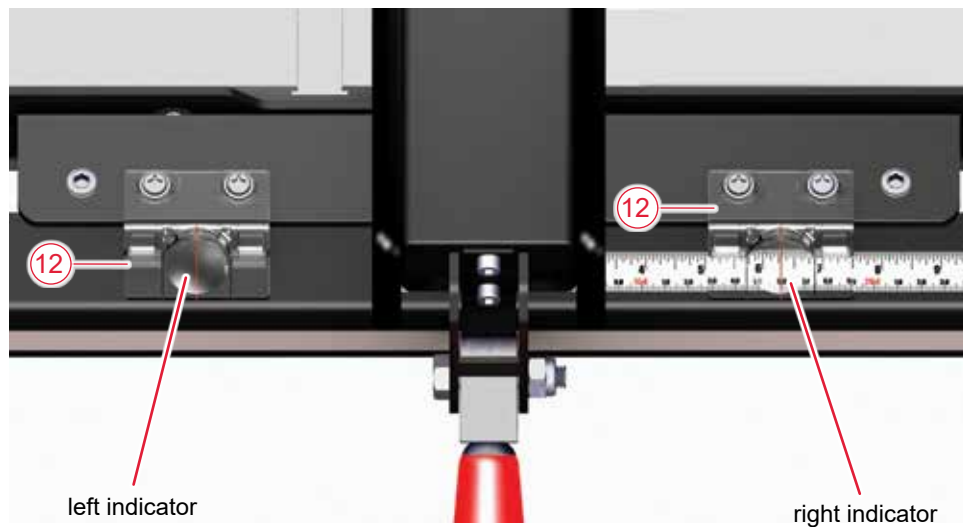

Fig. 30

If necessary, you can adjust the position of the indicator lenses on the front of the fence. To verify the position of each indicator lens, clamp the fence to the front tube and use a ruler to measure the distance from the blade to the fence plate and compare it to the measurement shown on the proper indicator lens. If adjustment is necessary, loosen the two M6 x 10 Phillips head screws (13) shown in Fig. 31 and slide the indicator lens to the right or left until the cursor is directly over the correct measurement. Tighten the screws to lock the position of the indicator lenses.

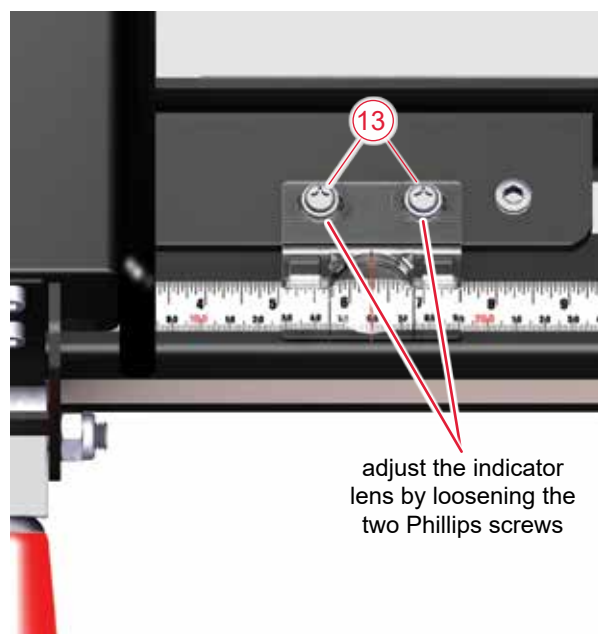

Fig. 31

**Parallel and Perpendicular:** The next step is to align the face plates (2) to be parallel to the miter slots. Begin by sliding the fence along the tube until the left face plate is flush with the right edge of the right miter slot. Lock the fence handle and check that the full length of the face plate is flush with the miter slot edge (Fig. 32).

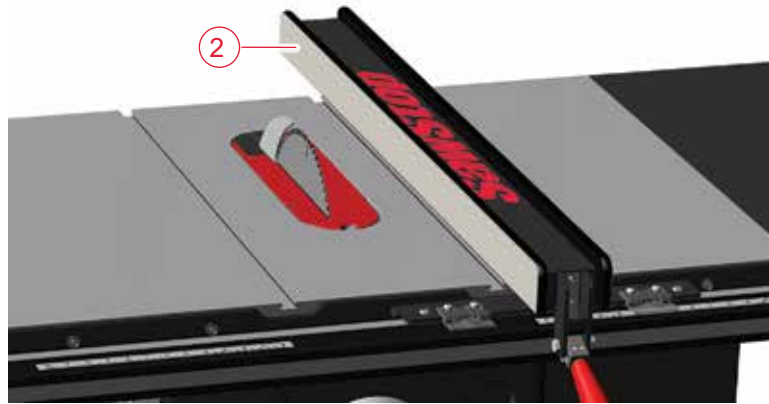

Fig. 32

If adjustment is required, use a 5 mm hex key to turn one of the two parallelism adjustment screws (11) (Fig. 27) until the faceplate is flush with the miter slot.

The next step is to adjust the face plates (2) to be perpendicular to the table top. The angle between the face plates and the table is set by the two plastic leveling screws (9) on top of the glide bracket (Fig. 33).

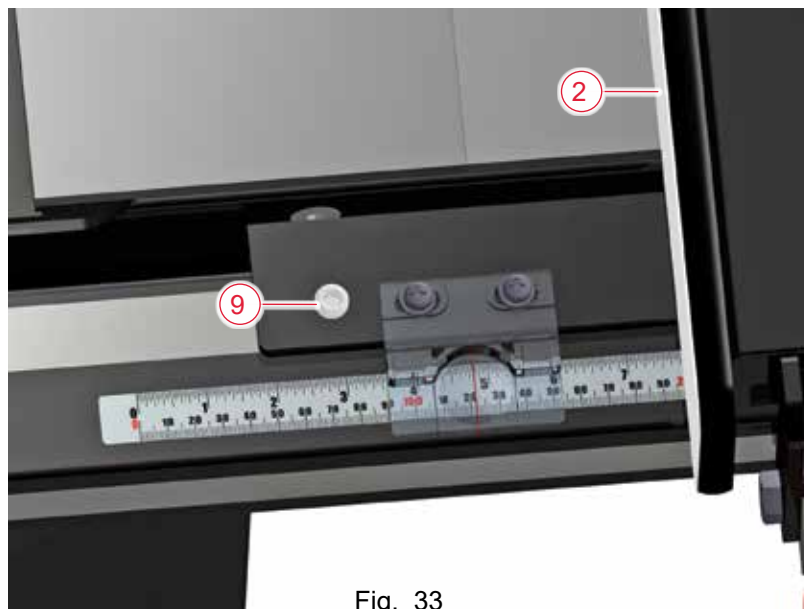

Fig. 33



Place a combination square on the table top and against the left fence face plate (Fig. 34). Use a 6 mm hex key to adjust the leveling screws (9) as necessary until the face plate is parallel to the vertical edge of the combination square.



Fig. 34

If necessary, you can adjust both of the plastic set screws (9) to ensure the position indicator lenses (12) are close to, but not touching, the main tube (8) or rulers (11, 12).

**Table Clearance:** The final step is to set the spacing between the bottom of each face plate and the table. The face plates are held in place by a series of screws threaded into nuts embedded in the face plates. The heads of the screws fit into key-hole slots in the sides of the fence (Fig. 35).

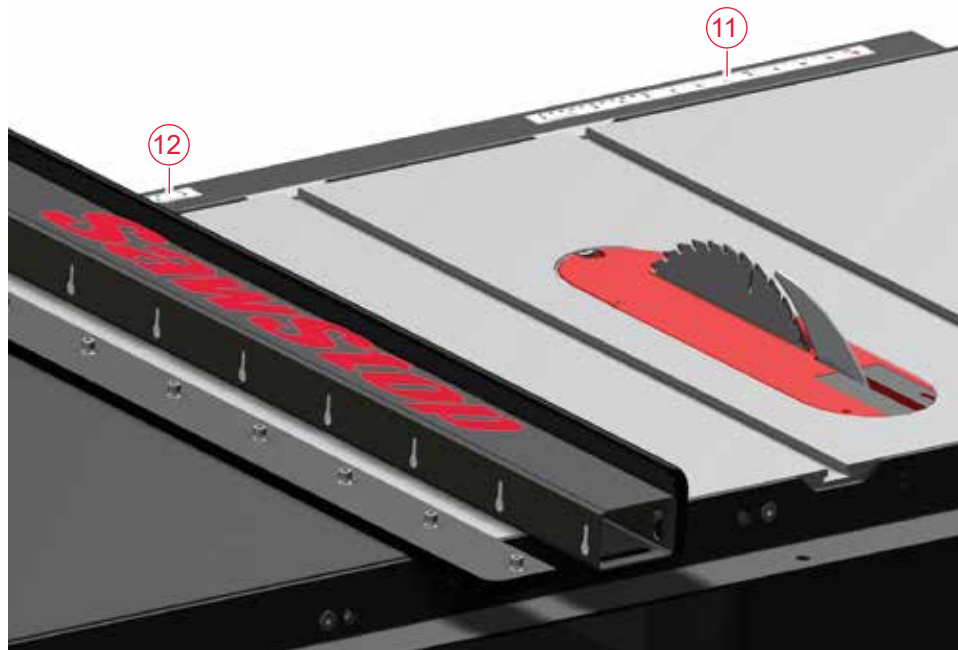

Fig. 35

It is usually possible to adjust the position of the face plates by lightly tapping the top or bottom edge of the face plates with a plastic or wooden mallet. However, if the face plates do not move when tapped, you can loosen the mounting screws as described below to adjust the face plates.

If the right face plate needs to be adjusted, you must first remove the left face plate. Begin by laying the fence on the table with the left face plate (L) facing down. You can access the screws for the left face plate through the slots on the bottom of the fence. Insert the 5 mm ball end hex driver through the slot at the end of the fence and into the screw head (Fig. 36). Loosen the screw about one-quarter to one-half turn but do not unthread it completely. Continue this process with each slot/screw pair. It may be helpful to shine a flashlight down the end of the tube to illuminate the screw heads. Once all the screws are loosened push the face downward to align the screw heads with the large portion of the key-hole slots, and then pull the face plate off the fence.

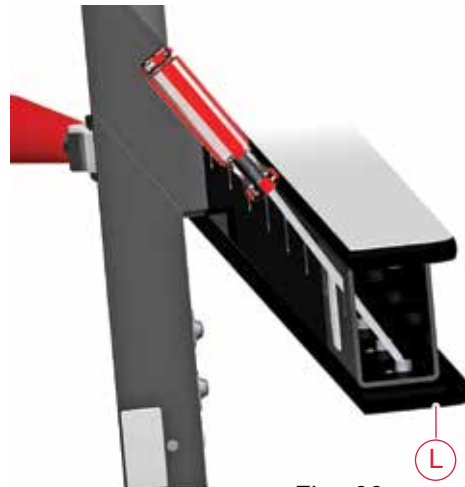

Fig. 36

Once the left face plate has been removed, you can access the screws for the right face plate through the key-hole slots for the left face plate (Fig. 37). Loosen each screw in the right face plate just enough to allow the face plate to slide against the fence tube. Install the fence on the main tube and position the right face plate as desired, making sure to leave at least a small gap between the bottom of the face plate and the table so the face plate does not drag on the table.

Next, lift the fence off the main tube and place it on the table with the right face plate facing down. Make sure not to move the face plate from the position you set. If necessary you can clamp the face plate to the fence to keep the face plate from moving. Tighten each screw to lock the right face plate in position. ***Make sure not to over-tighten these screws as this may cause a slight concavity in the surface of the face plate near the screw.***

Replace the left face plate onto the fence and install the fence on the main tube. Adjust the position of the left face plate as desired. Lift the fence off the tube and set it on the table with the left face plate down, making sure the position of the face plate doesn't move. Tighten the screws to lock the left face plate onto the fence. Your fence is now fully adjusted and ready to use.

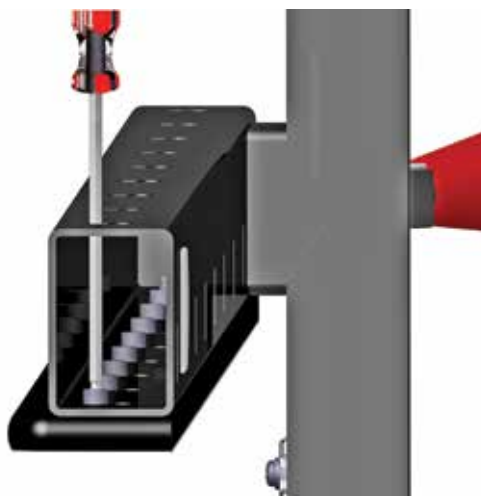

Fig. 37



## **Using Your T-Glide Fence System**

The rip fence included with your T-Glide Fence System is used to guide material parallel to the blade when you make rip cuts (cuts that are length-wise along the grain of the wood). The fence must always be used when making rip cuts.

To use the rip fence, begin by placing it on the table so that the fence bracket is resting on the upper rear edge of the front tube. You can use the fence on either the left or right side of the blade for non-bevel cuts. If you plan to make bevel cuts, use the fence only on the right side to prevent the blade from possibly contacting the fence. After placing the fence on the rails, lift the red handle up to the unlocked position and slide the fence to the left or right until the distance between the blade and the fence is approximately equal to the desired width of cut. Adjust the position of the fence until the cursor on the indicator lens is directly over the desired width of the cut. Use the lens on the left when the fence is on the left side of the blade and use the lens on the right when the fence is on the right side of the blade. Once the fence is in the correct position, push the red locking handle down to the locked position (Fig. 38). The fence is now locked in place and ready for use.



Fig. 38

# SawStop T-Glide™ Fence Assembly

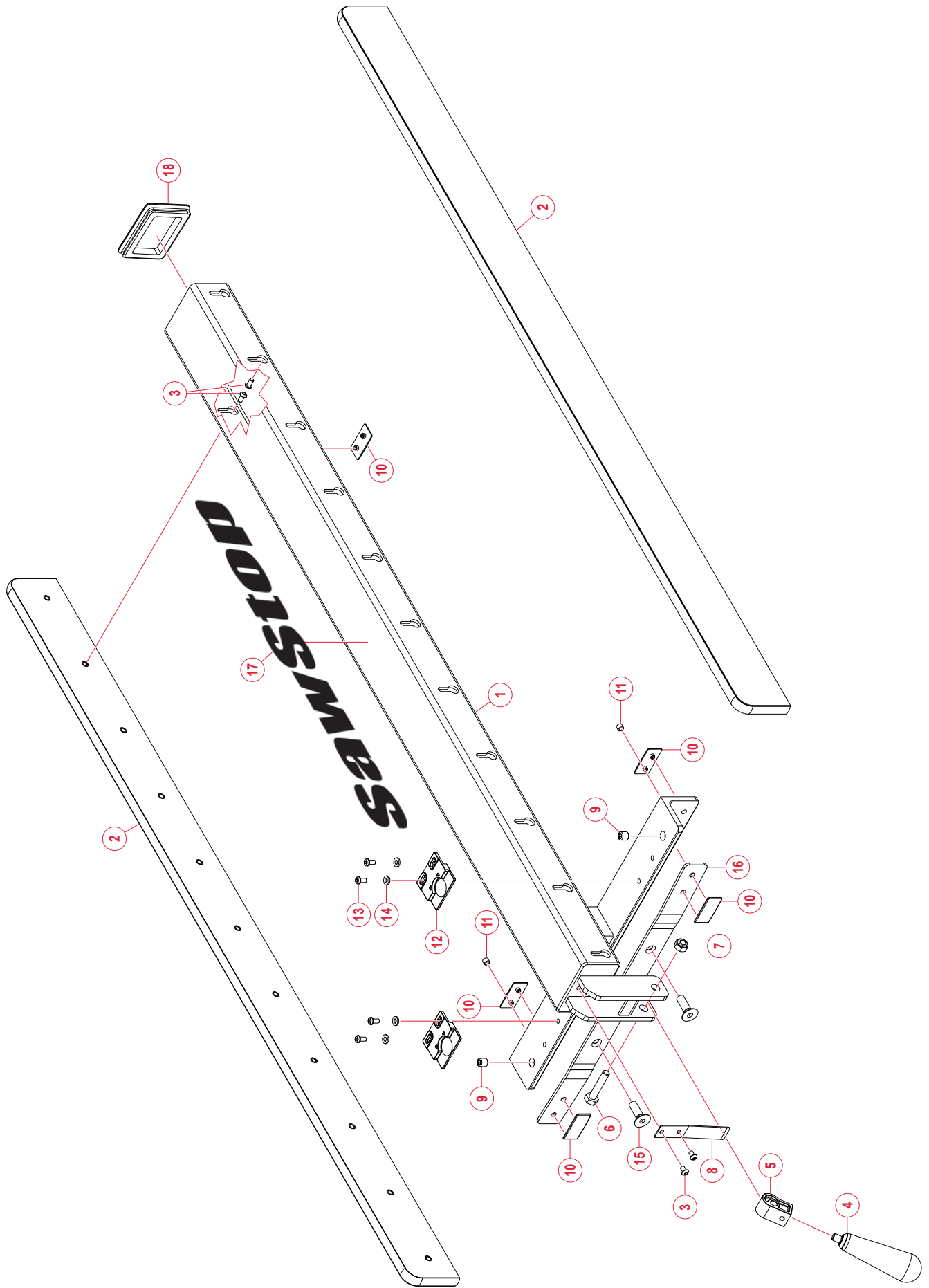

# Fence Assembly

| No.   | Description  | Part No.    | Qty. |
|---|--|-------------|------|
| <b>Purchase Assemblies</b>  |  |             |      |
| TGI2 - Industrial Series Fence Assembly and Rails - From date code 1731 and newer - Compatible with Router Tables |  |             |      |
|   | Industrial Series Fence Assembly and 36 inch Rails Assembly:<br>Consists of TGI2-FA, TGI2-T36A and TGI2-R36A | TGI2-FRT36A |      |
|   | Industrial Series Fence Assembly and 52 inch Rails Assembly:<br>Consists of TGI2-FA, TGI2-T52A and TGI2-R52A | TGI2-FRT52A |      |
| <b>Fence Assembly*</b>  |  |             |      |
| T-Glide Fence Assembly - From date code 1730 and newer - Compatible with Router Tables - Replaces CBF105 000      |  |             |      |
|   | T-Glide Fence Assembly (items 1-18 assembled)  | TGI2-FA     |      |
| 1   | Fence Tube   | TGI2-001    | 1    |
| 2   | Fence Face Plate   | TGI2-002    | 2    |
| 3   | M6x1.0x12 Socket Head Cap Screw  | TGI2-003    | 24   |
| 4   | Fence Handle   | TGI2-004    | 1    |
| 5   | Cam Lock   | TGI2-005    | 1    |
| 6   | M10x1.5x50 Hex Head Bolt   | TGI2-006    | 1    |
| 7   | M10x1.5 Lock Nut   | TGI2-007    | 1    |
| 8   | Flex Plate   | TGI2-008    | 1    |
| 9   | Leveling Adjustment Screw M12x1.75   | TGI2-009    | 2    |
| 10  | Glide Plate  | TGI2-010    | 5    |
| 11  | Parallelism Adjustment Screw M10 x 1.5 x 8   | TGI2-011    | 2    |
| 12  | Position Indicator Lens  | TGI2-012    | 2    |
| 13  | M6x1.0x10 Pan Head Phillips Screw  | TGI2-013    | 4    |
| 14  | M6 x 13 x 2 Washer   | TGI2-014    | 4    |
| 15  | M6 x 1.0 x 10 Flat Head Phillips Screw   | TGI2-015    | 2    |
| 16  | Flex Arm   | TGI2-016    | 1    |
| 17  | T-Glide Fence SawStop Label  | TGI2-017    | 1    |
| 18  | Fence Tube End Cap   | TGI2-018    | 1    |
| <b>Accessories</b>  |  |             |      |
| N/A   | TGI2 Owner's Manual  | TGI2-019    | 1    |
| N/A   | Hardware Bag for Rail Assembly (items 2-7)   | TGI2-020    | 1    |
| N/A   | 5mm Ball-end Hex Driver  | TGI2-021    | 1    |
| N/A   | 6mm Hex Wrench   | TGI2-022    | 1    |
| N/A   | Fence Installation Guide   | TGI2-023    | 1    |
| N/A   | Fence Attention Magnet   | TGI2-024    | 1    |

\*Each Fence box also contains the hardware for the Rail Assembly.

# SawStop 36" Rails and Extension Table

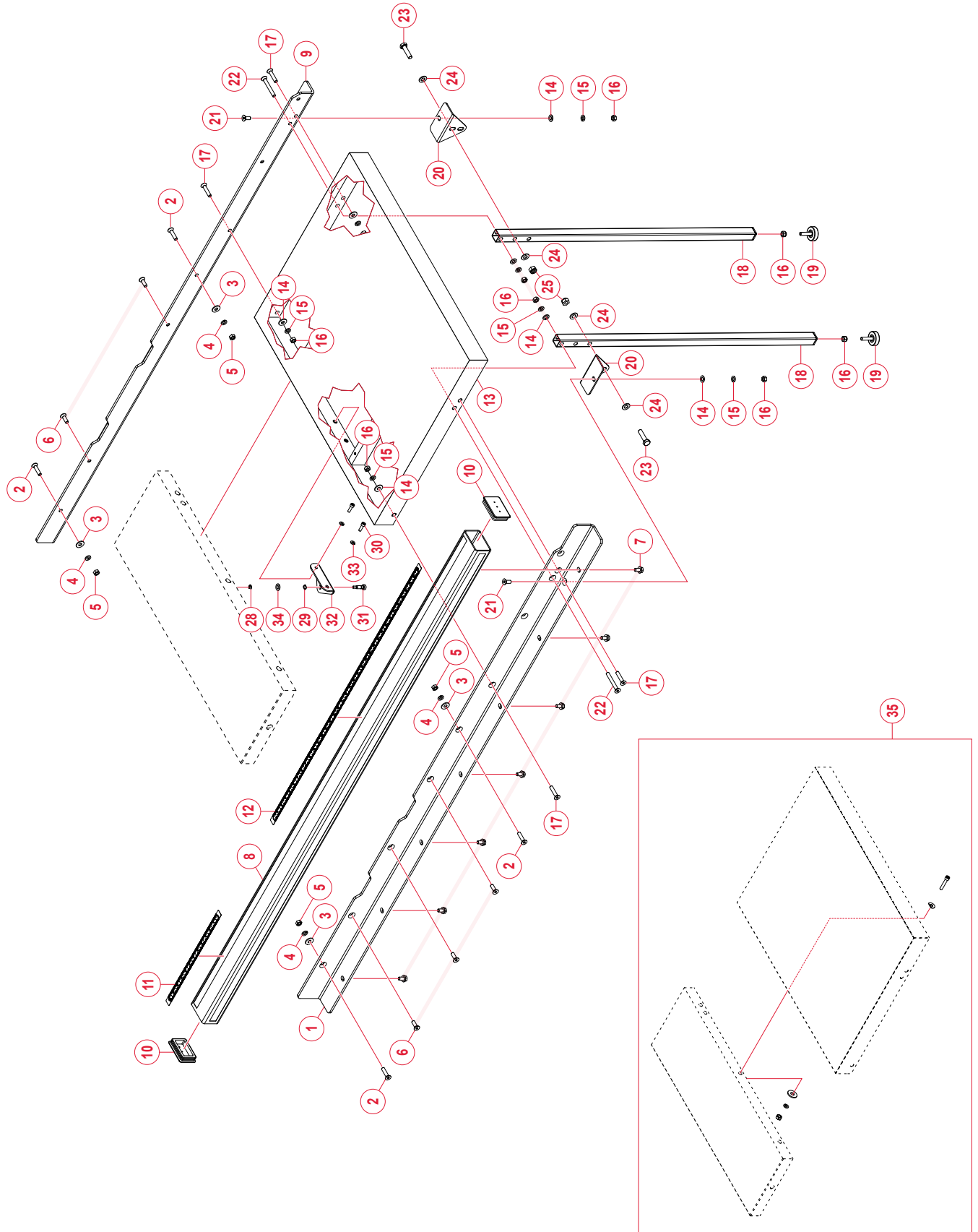

# 36" Rails and Extension Table Assembly

| No.  | Description   | Part No.     | Qty. |
|--|---|--------------|------|
| TGI2 Industrial Series 36" Rail Assembly - From date code 1731 and newer - Compatible with Router Tables - Replaces CBFR105 3600           |   |              |      |
|  | Industrial Series 36" Rail Assembly II  | TGI2-R36A    |      |
| 1  | 36" Front Rail  | TGI2-025     | 1    |
| 2  | M8 x 1.25 x 35mm Flat Head Socket Screw   | TGI2-026     | 4    |
| 3  | M8 x 23 x 2 Washer  | TGI2-027     | 4    |
| 4  | M8 Lock Washer  | TGI2-028     | 4    |
| 5  | M8 x 1.25 Hex Nut   | TGI2-029     | 4    |
| 6  | M8 x 1.25 x 25 Flat Head Socket Screw   | TGI2-030     | 5    |
| 7  | M8 x 1.25 x 16 Hex Head Bolt (w/ Captured Washer)   | TGI2-031     | 7    |
| 8  | 36" Main Tube   | TGI2-032     | 1    |
| 9  | 36" Rear Rail   | TGI2-033     | 1    |
| 10   | Main Tube End Cap   | TGI2-034     | 2    |
| 11   | 12" Ruler   | TGI2-035     | 1    |
| 12   | 36" Ruler   | TGI2-036     | 1    |
| N/A  | Hardware Bag for Rail Assembly (items 2-7)  | TGI2-020     | 1    |
|  | 36" Retrofit Assembly   | RT-TGI2-R36A |      |
| TGI2 Industrial Series 36" Extension Table Assembly - From date code 1731 and newer - Compatible with Router Tables- Replaces CBFT105 3600 |   |              |      |
|  | Industrial Series 36" Extension Table Assembly  | TGI2-T36A    |      |
| 13   | 36" Extension Table   | TGI2-037     | 1    |
| 14   | M8 x 23 x 2 Washer  | TGI2-038     | 8    |
| 15   | M8 Lock Washer  | TGI2-039     | 8    |
| 16   | M8 x 1.25 Hex Nut   | TGI2-040     | 10   |
| 17   | M8 x 1.25 x 40mm Flat Head Socket Screw   | TGI2-041     | 4    |
| 18   | Support Leg   | TGI2-042     | 2    |
| 19   | Leveling Foot   | TGI2-043     | 2    |
| 20   | Leg Support Bracket   | TGI2-044     | 2    |
| 21   | M8 x 1.25 x 20 Flat Head Socket screw   | TGI2-045     | 2    |
| 22   | M8 x 1.25 x 65 Flat Head Socket Screw   | TGI2-046     | 2    |
| 23   | M10 x 1.5 x 45 Hex Head Bolt  | TGI2-047     | 2    |
| 24   | M10 x 25 x 1.5 Washer   | TGI2-048     | 4    |
| 25   | M10 x 1.5 Lock Nut  | TGI2-049     | 2    |
| 28   | 6mm E-Style Retaining Ring  | TGI2-067     | 1    |
| 29   | M8x12.5 Wave Washer   | TGI2-068     | 1    |
| 30   | M6x1.0x18 Socket Head Cap Screw   | TGI2-069     | 2    |
| 31   | M6x1.0x32 Socket Head Shoulder Adjustment Screw   | TGI2-070     | 1    |
| 32   | Adjustment Bracket  | TGI2-071     | 1    |
| 33   | M6 Lock Washer  | TGI2-072     | 2    |
| 34   | M8x16x1.5 Washer  | TGI2-073     | 1    |
| N/A  | Hardware Bag for 36 inch Extension Table Assembly for TGI2 (items 14-17, 21-25, 28-34)    | TGI2-059     | 1    |
| 35   | Supplemental Mounting Kit (for TGI2 tables with older date codes that do not use item 32) | TGI2-WA-001  | 1    |

\*Each Fence box contains one bag of hardware for a 52" Rail Assembly. If you purchased a 36" Rail Assembly, you can disregard the extra hardware.

# SawStop 52" Rails and Extension Table

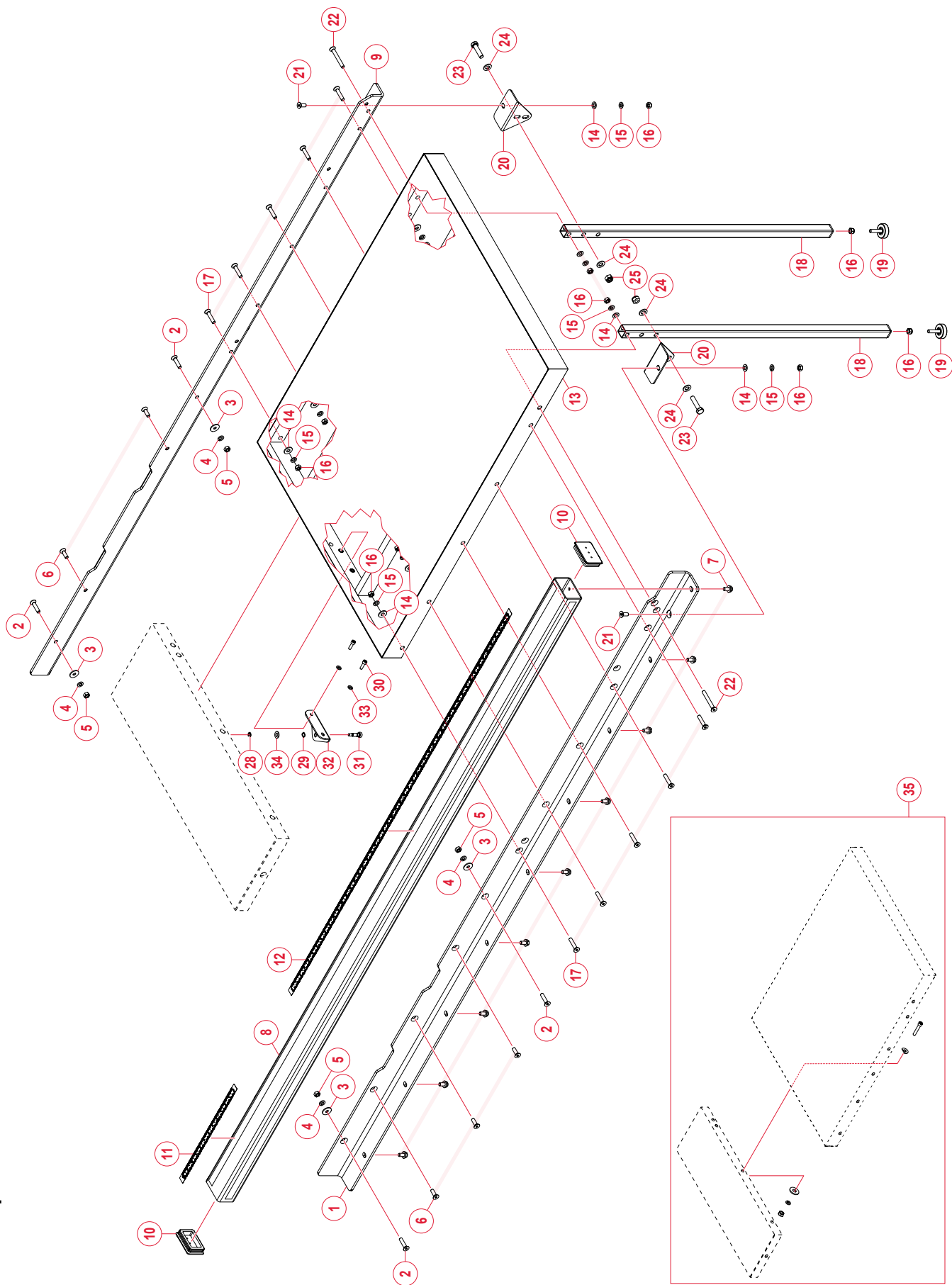

# 52" Rails and Extension Table Assembly

| No.   | Description   | Part No.     | Qty. |
|---|---|--------------|------|
| TGI2 Industrial Series 52" Rails Assembly - From date code 1731 and newer - Compatible with Router Tables - Replaces CBF104 5200            |   |              |      |
|   | Industrial Series 52" Rails Assembly  | TGI2-R52A    |      |
| 1   | 52" Front Rail  | TGI2-060     | 1    |
| 2   | M8x1.25x35 Flat Head Socket Screw   | TGI2-026     | 4    |
| 3   | M8x23x2 Washer  | TGI2-027     | 4    |
| 4   | M8 Lock Washer  | TGI2-028     | 4    |
| 5   | M8x1.25 Hex Nut   | TGI2-029     | 4    |
| 6   | M8x1.25x25 Flat Head Socket Screw   | TGI2-030     | 5    |
| 7   | M8x1.25x16 Hex Head Bolt (w/ Captured Washer)   | TGI2-031     | 9    |
| 8   | 52" Main Tube   | TGI2-061     | 1    |
| 9   | 52" Rear Rail   | TGI2-062     | 1    |
| 10  | Main Tube Endcap  | TGI2-034     | 2    |
| 11  | 12" Ruler   | TGI2-035     | 1    |
| 12  | 52" Ruler   | TGI2-063     | 1    |
| N/A   | Hardware Bag for Rail Assembly (items 2-7)  | TGI2-020     | 1    |
|   | 52" Retrofit Assembly   | RT-TGI2-R52A |      |
| TGI2 Industrial Series 52" Extension Table Assembly - From date code 1731 and newer - Compatible with Router Tables - Replaces CBFT104 5200 |   |              |      |
|   | Industrial Series 52" Extension Table Assembly  | TGI2-T52A    |      |
| 13  | Table   | TGI2-064     | 1    |
| 14  | M8x23x2 Washer  | TGI2-038     | 15   |
| 15  | M8 Lock Washer  | TGI2-039     | 15   |
| 16  | M8x1.25 Hex Nut   | TGI2-040     | 17   |
| 17  | M8x1.25x40 Flat Head Socket Screw   | TGI2-041     | 10   |
| 18  | Support Leg   | TGI2-042     | 2    |
| 19  | Leveling Foot   | TGI2-043     | 2    |
| 20  | Leg Support Bracket   | TGI2-044     | 2    |
| 21  | M8 x 1.25 x 20 Flat Head Socket Screw   | TGI2-045     | 2    |
| 22  | M8 x 1.25 x 65 Flat Head Socket Screw   | TGI2-046     | 2    |
| 23  | M10 x 1.5 x 45 Hex Head Bolt  | TGI2-047     | 2    |
| 24  | M10 x 25 x 1.5 Washer   | TGI2-048     | 4    |
| 25  | M10 x 1.5 Lock Nut  | TGI2-049     | 2    |
| 28  | 6mm E-Style Retaining Ring  | TGI2-067     | 1    |
| 29  | M8 x 12.5 Wave Washer   | TGI2-068     | 1    |
| 30  | M6 x 1.0 x 18 Socket Head Cap Screw   | TGI2-069     | 2    |
| 31  | M6 x 1.0 x 32 Socket Head Shoulder Adjustment Screw                                       | TGI2-070     | 1    |
| 32  | Adjustment Bracket  | TGI2-071     | 1    |
| 33  | M6 Lock Washer  | TGI2-072     | 2    |
| 34  | M8x16x1.5 Washer  | TGI2-073     | 1    |
| N/A   | Hardware Bag for 52 inch Extension Table Assembly for TGI2 (items 14-17, 21-25, 28-34)    | TGI2-065     | 1    |
| 35  | Supplemental Mounting Kit (for TGI2 tables with older date codes that do not use item 32) | TGI2-WA-001  | 1    |

SawStop, LLC  
11555 S.W. Myslony Street  
Tualatin, Oregon 97062  
[www.sawstop.com](http://www.sawstop.com)

Main Phone - (503) 570-3200  
Service - (503) 582-9934  
Fax - (503) 570-3303  
Email: [info@sawstop.com](mailto:info@sawstop.com)

Updates of this manual may be available at [www.sawstop.com](http://www.sawstop.com).

Copyright SawStop, LLC. All Rights Reserved.  
SawStop is a registered trademark and T-Glide is a trademark of SawStop, LLC.

March 2019  
M ICS 19 0001 00